

OPERATING INSTRUCTIONS



systemco[®]
cleaning technology

systemco Vertriebs GmbH
Herbartstraße 28
D-14057 Berlin
fon +49 30 3270-2157
fax +49 30 3270-2134
info@sys-teco.de
www.sys-teco.com

We expressly point out that legal claims of any kind relating to the statements in this manual may not be invoked.

In case a repairing of the machine is necessary, use original replacement parts only. Only these are able to guarantee a perfect quality and reliable readiness for application of your machine. We do not assume liability for the usage of any replacement parts of other manufacturers.

Subject to change

valid from 06.01.2017

systemco Vertriebs GmbH
Herbartstr. 28
14057 Berlin

Tel +49 30 3270-2157
Fax +49 30 3270-2134
info@sys-teco.de
www.sys-teco.com

Attention

Read and consider these operating instructions carefully before the first start up procedure! Apart from the references, in these operating instructions the general rules for safety and prevention of accidents of the legislator have to be taken into consideration.



The operating instructions describe the functioning, application and handling of the Tornado ACS and give advice for the selection of the appropriate blasting material as well as it helps in problematic cases.

Table of contents

Intended application	4
Taking charge of the machine	4
Structure of the Tornado ACS and functional principle	5
Start-up procedure and functioning	6
Filling with blasting media	6
Preparing the machine	7
Emptying of used blasting media	8
Important advices for maintenance and operating instructions	9
Changing of filter cartridge	9
Change of dosage	10
Application of filter	10
Electricity supply	10
Application of jet hood	11
Examples for practical use	12
Possible reasons for failures	17
Specifications	17
EU-Declaration of Conformity	18

Enclosures

Customer benefits
 Advantages
 Safety instructions
 Granulate application chart
 Flyer graffiti removal
 Flyer fire damage restoration
 Flyer protected faced
 Flyer highway maintenance
 Flyer thermal bath
 Flyer stonemason

Intended application

The mobile jet-system Tornado ACS operates with the worldwide patented negative pressure jet principle and consists of only one compact mobile machine. By the use of suitable blasting media (granulate) of different grain and structure it facilitates a radiation with retrieval of the jet grain being dust-free and low in noise.

The machine contains a generator for negative pressure with a filter cartridge and dust separation as well as an appropriate container for the blast material. Further components of the system are the lighted jet cap and the jet lance.

The fields of **applications** are various and are selected by different criteria like:

Subsoil	clinker, concrete, sandstone, wood, plastic, metal, tiles, facades
Removal	strong or in layers
Contamination	graffiti, rust, lime stone, saltpetre, weathering etc.

Possible applications: Industrial cleaning, craft of painting or lacquering, housing cooperative, repair and maintenance of cars, the building industry. The Tornado ACS is used for cleaning, removal of layers and lacquer, de-rusting, roughening up and restoring of surfaces. The use of the system is possible in interiors, but also on hydraulic platforms or scaffolds without special preparation. Therefore a sufficient stability of the system has to be considered!



The application is not admissible in rooms or environments being endangered of explosion. There is no permission for using the system to clean animals or persons.

The compliance with conditions given by the manufacturer on maintenance, operation and repairing is part of the correct use. Due to improper application the liability will be excluded. The regulations on preventing accidents and any further generally known security technology according to occupational health supervision must be observed. The manufacturer's liability is also excluded for damages which are the result of unauthorized changes on the system. The user is responsible for third persons in the work area. If the equipment is not ready for work, it may not be used. It is essential to make oneself familiar with all mechanisms and controls as well as with their function before start up. The equipment is never to be left unsupervised, as long as the suction device is running. In order to prevent an unauthorized use of the equipment, the power supply plug has to be taken off.

Taking charge of the machine

The machine has to be checked on completeness and possible damages caused by transport immediately after its arrival. Such damages are replaced when a confirmation of the forwarding agent and the freight papers are send to systeco GmbH.

Structure of the Tornado ACS and functional principle

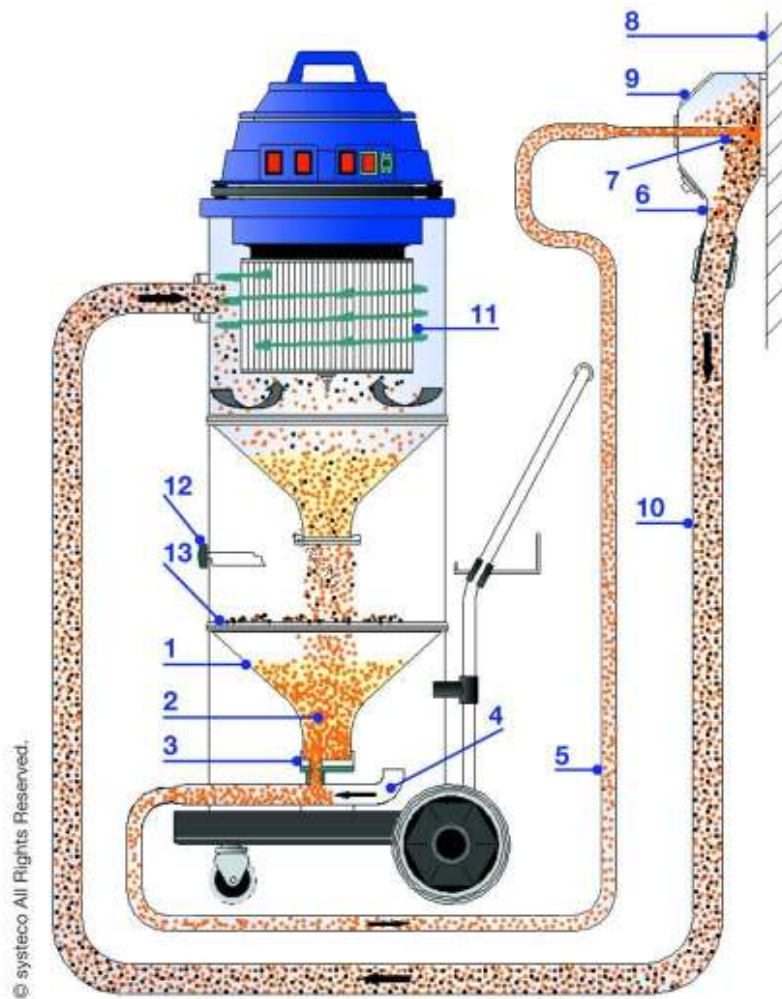

After turning on, the **jet hood (6)** is placed on the **surface (8)** and adheres to it by the vacuum. With inserting the **jet lance (7)** into the **jet hood (6)** the cycle is closed. By gravity the **granules (2)** are passed through from the **lower container (1)** to a **dosing system (3)** into the **air flow (4)**. Due to the vacuum the **granules (2)** are then transported through a **flexible suction hose (5)** to the **jet cap (6)**. Through the **jet lance (7)** the granules impinge onto the **surface (8)** to be worked on. By moving the **jet lance (7)** the surface can be cleaned quickly and dust-free, stripped or roughened up. The process can be optimally monitored and controlled via 3 **vision panels (9)**. After impinging, the **granules (2)** and the removed debris are sucked in immediately. Through the **suction hose (10)** the abrasive mixture enters the upper part of the machine. There, it is separated in the **fine dust filter (11)** by the cyclone principle, and falls into the middle container of the Tornado ACS. By opening the **flap (12)** the granules fall through the **screen (13)**, on which coarse particles are kept, into the **lower container (1)**, where it is supplied for reuse.

Startup procedure and functioning

1. Put in plug
2. Switch on lighting
3. Fill or suck in blasting media

Filling with blasting media



Never fill the container for granules completely! Tense the containers tightly with the metal clamps which are supposed for that. After being a long time not using it for a long time the blasting media has to be removed of the medium container.

The dosing frame (*see also page 10*) has to be selected depending on grain and structure of the blast media. Aperture 5 is factory-adjusted (*see also advices on the application chart for using blast media*).

- separate suction hose with hose coupling from jet cap
- switch on suction device (3 steps - one after the other)
- dip end of hose into granulate material box and suck up jet material
- switch off suction device
- connect suction hose with jet hood again
- loose flap and arrest it again

or

- take suction head off media tower
- fill in blasting media
- put on suction head
- **loosen flap (12)** and arrest it again

then

4. Switch on suction device (3 steps - one after the other)
5. Take the jet cap in your hand and put it onto working surface – jet cap will adheres itself
6. Insert jet lance into jet hood
7. Jet process begins - steady moving of the jet lance
8. Between working surface and jet lance, pay attention to keep a distance of about 5 cm
9. Entire surface radiated (limited by the jet hood)
10. Operate air flap in jet cap, cap loses itself, then move
11. When moving the jet process automatically discontinuous
12. Whole jet plast in the middle container, switch off suction
(*see also preparing the machine, page 7*)
13. Work is finished, jet hood with jet lance file, Tornado ACS and lighting switch off

By switching on the negative pressure generator (industrial suction-head) a negative pressure of approx. 150 - 170 mbar is produced in the jet cap. The jet hood itself is set on the working surface and adheres to due to the negative pressure. By inserting the jet lance the cycle is closed. Blasting media is sucked in the jet lance and accelerated to more than 400 km/h. Thus the operating surface is cleared as required, layers are removed or it is roughened up. Due to the 3-step operation of the negative pressure generator the results can be adapted to requirement.

Preparing the machine

1. Switch off suction device
2. Loosen flap and wait some seconds until blasting media got from middle container into dosing tank
3. Lock flap
4. Switch on suction device again (every step separately)

Middle container with funnel and pneumatic division

see flap (12)

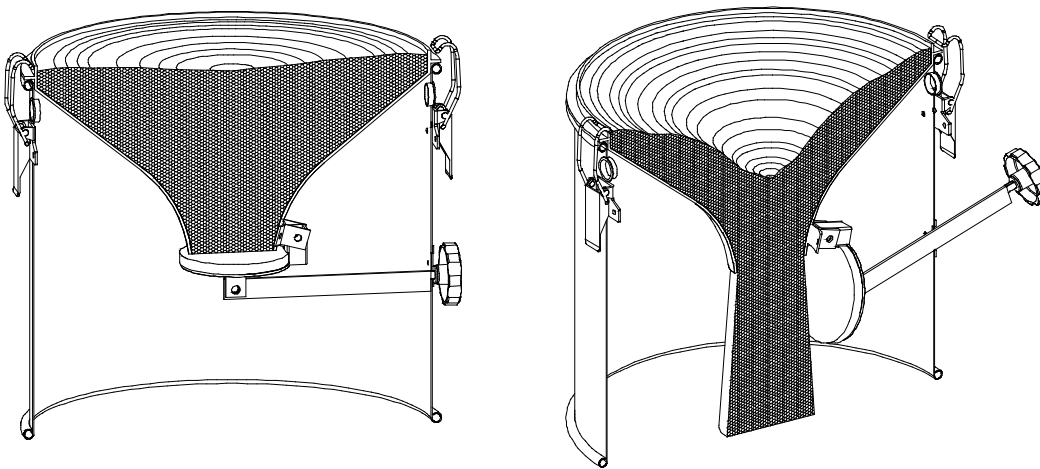

For opening flap, loose star knob (2-3 rotations) and hold it up slightly. The reusable or new blast grain will get into the jet material container (lower container). Hold the star knob up and press it in direction of container again for closing the flap. Tighten star knob.



The flap has to be completely closed, since otherwise negative pressure cannot be produced.

Emptying of used blast media

1. Operate until blasting media is completely transported into container above the flap
2. Separate media tower below the flap
3. Suck blasting media of the bottom container with the suction hose until it is completely empty
4. Remove upper container of the media tower
5. Place the funnel of the lower container into granulate bucket
6. Set the middle container with flap onto the funnel
7. Open flap and fill back the granulate into the bucket
8. Reassemble media tower

Special advices:

When changing the blasting media the whole system has to be cleaned completely of the jet material used so far, otherwise damages on sensitive surfaces could occur. The cleaning is necessary for all suction hoses, jet hood and –lance as well as containers and dosing equipment.



Keep blasting media always dry and in a closed box. Remove possibly escaped blast media of the floor (sweep or suck up).

Please consider local conditions for the disposal of colour residues or granulate material.

Cleaning video TORNADO ACS

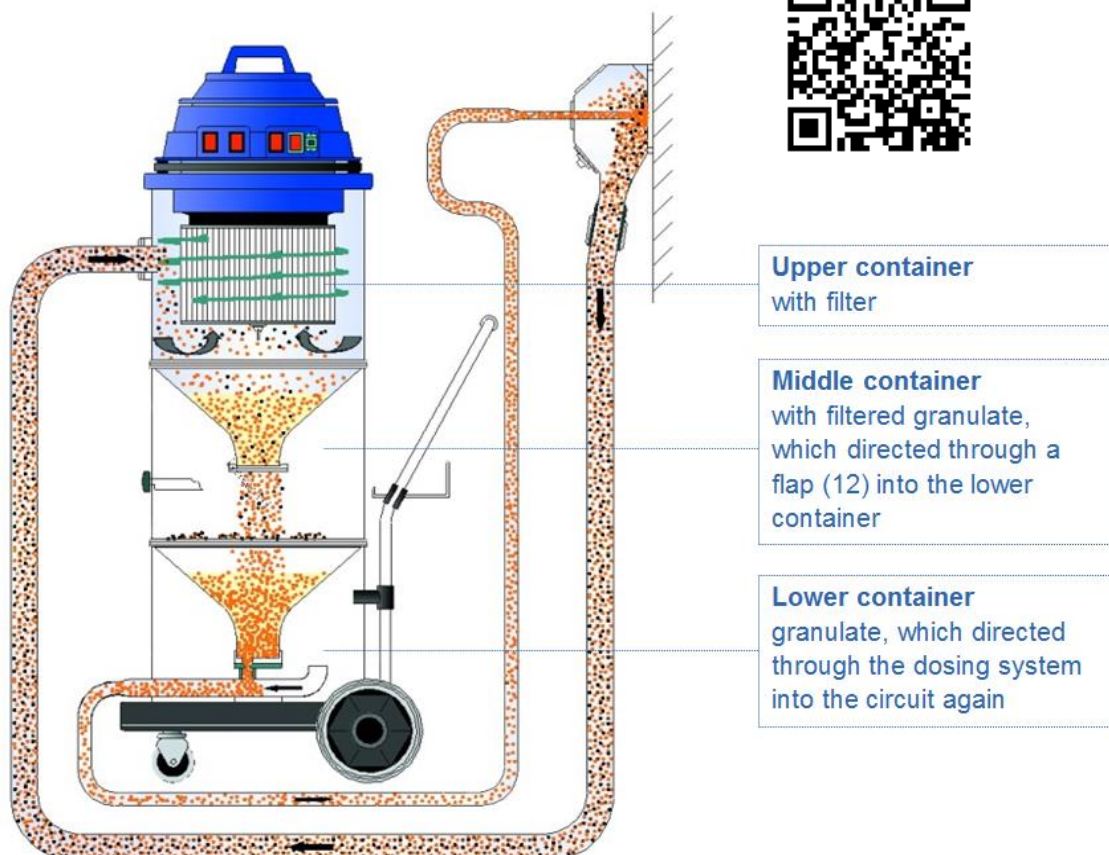

Important advices for maintenance and operating instructions

- Before turning on the Tornado, close flap.
- Clean or change **filter cartridge 1.3** (suction head **1.1**) after approx. 4h.
- Remove worn out granulate and dirt residues from **collection pan 1.4**.
- The blasting media wears out, the longer it is in use. Depending on the kind of granulate it can be reused 40 to 100 times. The wear is possible to recognize by the condition of the granulate material. When it is worn out it is necessary to exchange it completely for jet material.
- The **vision panels (9)** at the jet hood are turning blind after approx. 40 to 80 working hours depending on the used granulate. They have to be exchanged according to requirement (poor visibility).
- The time for radiation depends on the size of operating surfaces, strength of lacquer and its structure and on the blasting media which is applied. This time can be substantially shortened by periodically working with the machine and the experience which will be gained.

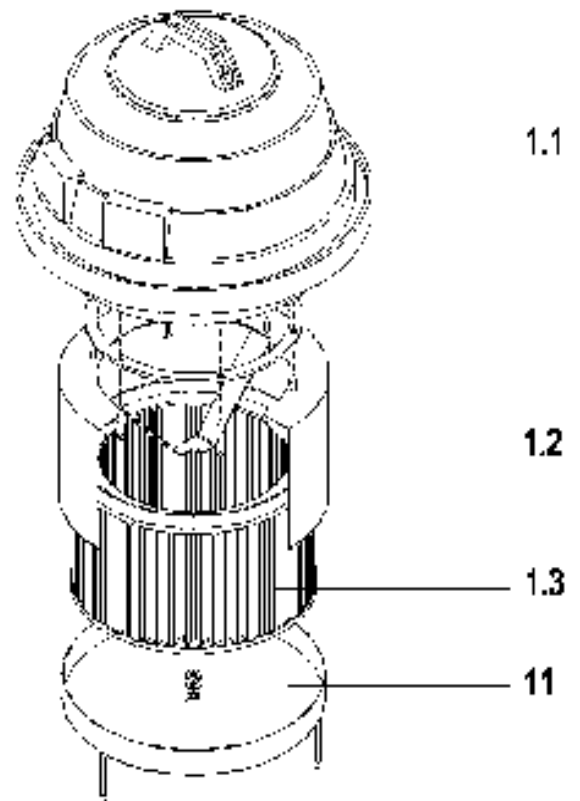

Changing the filter cartridge

1. Switch off suction device
2. Pull out the plug from power supply
3. Remove **suction head 1.1** (*see page before*) by opening metal clamps
4. Take off upper container with **suction head 1.1**
5. **Filter cartridge 1.3** is now easily accessible
6. Loosen the wing nut
7. Detach filter cartridge, clean or exchange it.

When installing the filter cartridge, you have to pay attention that the sealing washer of the filter cartridge is resting flat on the dip tube. This can be checked by a slight rotation of the filter cartridge in the inserted state. The wing nut is hand tightened firmly. If the filter cartridge is not used correctly, dirt and granules can get into the engine, which can lead to the destruction of the motor head.

Cleaning the filter cartridge

After operating for approx. 4 hours, clean or change the filter, it can be swept, beaten or vacuumed. The filter can also be cleaned with water, but has to be dry before the next usage.

Change of dosage

Before shifting the dosage, **funnel 2** has to be empty!

1. **Dosage 3** is located in the lower container
2. Solve both metal clamps in the lower container
3. The rest of the machine can be lifted
4. Take **filter 1** out, dosage accessible
5. Lift slightly **dosage 3**, turn according to desired position
6. Dosage locks in
7. Put on **filter 1**, complete upper part by putting on the top, brace metal clamps

To find out which dosing to use, please refer to the application table enclosed.

Insert sieve

Installing or changing the filter is similar to the changing of the dosing frame. The filter protects the **dosage 3** before the pollutions which can lead to the disturbance or to the failure of the device

Use always only one **sieve 1!**

Select the filter depending on the grain size of the blast media:

Coarse sieve:

Sieve grain size → more than 0.3 mm

Fine sieve: → less than 0.3 mm

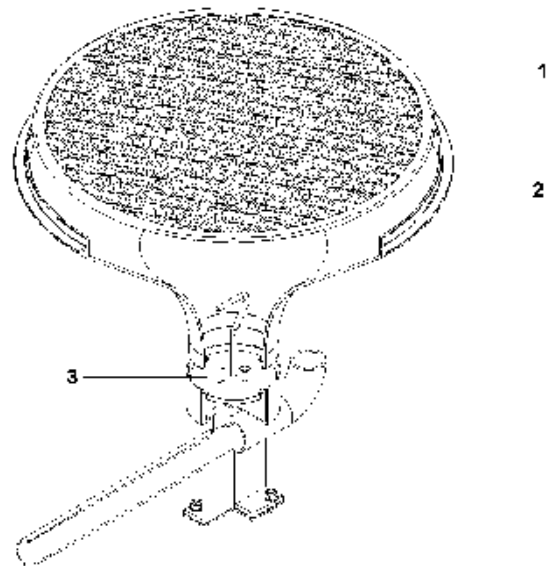

Power supply



The suction head has a power connection and has to be attached to the power supply system before startup. For the application at least 2 suction steps have to be switched on.



When the connection power cable is damaged it must be changed by an electrical specialist. The use of a minimum cross section suitable ampere has to be ensured.

When using power supply for the suction device together with an extension cable of more than 10 m, the extension cable must have an extended lead cross section at least. It is recommended to run out the cable drum completely, to avoid a superheating and damages or break-downs as a result of this.

Application of jet hood

1. Put the **jet hood (6)** on the surface to be worked on (according to the picture)
2. Due to the negative pressure the jet cap adheres to it immediately
3. Insert **jet lance (7)** and bring it close to the surface
4. Optimum distance to the working surface is **approx. 5 cm**
5. Working process is controllable with the help of three **vision panels (9)**
6. Move jet lance constantly – until desired result is achieved
7. Take off the jet hood from the surface by opening the **air flap** beneath the jet cap (the blasting process is automatically interrupted)

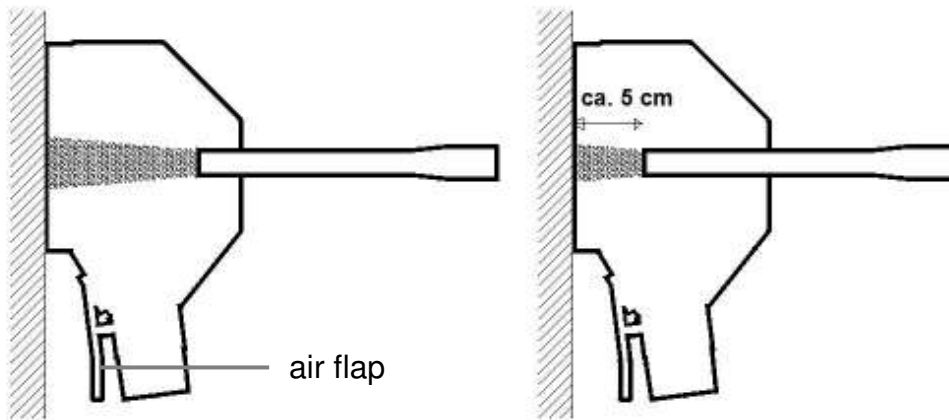

Note: Tilt the jet hood at the top first, so that residues of blasting media are collected and sucked off.

Examples for practical use

In the following examples some possible applications are described. The selection of granulate as well as the setting of the dosing. These information's are guidelines for the optimum use.

Application on roughcast

All finery infiltrated with colour can be worked on without problems. If the front is painted it depends on the quality of the paint. Above all, heat compound systems can be cleaned very well.

granulate	jet glass SG 150
dosage	nozzle 5 - 6
usage	approx. 80 - 100 times
efficiency	3 - 4 m ² per hour
motor-stage	1 - 2



Application on brick

Clinker fronts can be cleaned particularly easy. The work can be done very fast and the grouts are completely clean.

With this procedure the bricks surface will not be affected no matter whether graffiti, discolorations or efflorescence should be removed.

granulate	asilit AS 90 / 250
dosage	nozzle 5 - 6
usage	approx. 80 - 100 times
efficiency	3 - 5 m ² per hour
motor-stage	2 - 3



Application on painted facades

Coloured fronts are treated depending on the kind of surface and its background.

Basically: The more uneven the surface the more difficult it is to clean without damaging the colour.

The Tornado ACS cleans selective rust stains on walls quickly and carefully.

granulate	jet glass SG 150
dosage	nozzle 5 - 6
usage	approx. 80 - 100 times
efficiency	3 - 4 m ² per hour
motor-stage	1 - 2



Application on tiles

With jet glass 150 you can clean deep into the pores of tile stairs with safety grooves.

Even indoors the Tornado can be used well for Brick cleaning and tile mainly because it works dust-free.

granulate	jet glass SG 150
dosing	nozzle 5 - 6
usage	approx. 80 – 100 times
efficiency	3 m ² per hour
motor-stage	2 - 3



Application on plastic

Graffiti on distribution boxes made of plastic can be removed. Since the Tornado ACS works in a closed system, there are no protective clothing and barriers necessary.

granulate	jet glass SG 150
dosing	nozzle 6 - 8
usage	approx. . 50 – 70
efficiency	2 - 3 m ² per hour
motor-stage	2 - 3



Working on surfaces with foil

In this example, a steel door is cleaned from graffiti-painting. On the door text foil is glued on. Despite using hard grains, the foil is not damaged since it is soft and absorbs the energy of the impinging granulate.

granulate	jet glass SG 300
dosage	nozzle 5 - 6
usage	approx. 80 - 100 times
efficiency	3 - 4 m ² per hour
motor-stage	2 - 3



Application on metal

On metal graffiti pollutants are cleaned thoroughly with granulate. Here you can also use rough granulate. Depending on the granulate, the surface structure of the material changes. To remove color markings, or to accomplish a metal surface the Tornado ACS is exactly the right solution.

granulate	asilit AS 250
dosing	nozzle 6
usage	approx. 80 - 100
efficiency	3 - 4 m ² per hour
motor-stage	3



Application on natural stone

On this sample a facade made of natural stone is freed of graffiti. Irregularities up to 3 cm can be easily compensated with the jet hood.

granulate	asilit AS 250
dosage	nozzle 5 - 6
usage	approx. 80 - 100
efficiency	3 - 4 m ² per hour
motor-stage	2 - 3



Application on sandstone

Sandstone is very sensitive. A cleaning of the surface is only possible if color or pollution are not drawn into the stone and no chemical bond with the subsurface took place.

Mainly fine granules are used. It is always to start with one motor. Polished surfaces always must be treated with nutshell granulate. With the use of glass granules or ASILIT the surfaces turn dull.

For this very delicate surface, the Tornado ACS cleaning technology is ideally suited.

granulate	jet glass SG 150 (light subsurface) asilit 90 (dark subsurface)
dosing	nozzle 5 - 6
Usage	approx. 80-100
efficiency	3 - 4 m ² per hour
motor-stage	1 - 2



Application on wood

The cleaning of half-timbered houses is possible as well as the use on wood. On clinker and on wood fine blast media is used. Therefore the Tornado ACS suits ideally for both surfaces.

granulate	jet glass SG 150
dosage	nozzle 5 - 6
usage	approx. 80-100
efficiency	3 - 4 m ² per hour
motor-stage	2 - 3



Paint removal from boats

Small boats can be easily stripped with hard blasting abrasives. You can set a clean edge. The boat does not have to be in a hall for this.

granulate	asilit AS 500
dosage	nozzle 8 - 11
usage	approx. 80 - 100
efficiency	1 - 2 m ² per hour
Motorstufen	3



Joint Cleaning

The joints are cleaned without damaging them or the tile.

granulate	nutshell NS 450
dosage	nozzle 6-8
usage	approx. 80 - 100
efficiency	1 - 2 m ² per hour
motor-stage	2 - 3



Possible reasons for failures

malfunctioning	possible reason
suction device does not start up	<ul style="list-style-type: none"> electricity supply (230 V or 110 V) is not correct
substantial deterioration of blasting time	<ul style="list-style-type: none"> filter at the suction device is very dirty jet material is extensively worn out leaks at jet cap, connections or tubes only 2 stages switched on one motor broke down
no visible transport of granules	<ul style="list-style-type: none"> leaks of jet cap, connections or tubes no jet material in the dosing tank no jet material filled in at all open flap large foreign bodies in the dosage suction engine broke down wrong adjustment of dosing device
no or insufficient abrasion	<ul style="list-style-type: none"> use of wrong blasting media (not abrasive enough) motor power too low (use all 3 motors) filter dirty
excessive abrasion	<ul style="list-style-type: none"> use of wrong blasting media (too abrasive) motor power too high (reduce output by using only 1 or 2 motors)

Specifications

Tornado ACS 35	230 V / 50-60 Hz / 3.500 W (EU)
Tornado ACS 30	115 V / 50-60 Hz / 3.300 W (GB)
Tornado ACS 28	120 V / 50-60 Hz / 2.800 W (USA/CA)
Tornado ACS 36	250 V / 50-60 Hz / 3.500 W (AUS)

negative pressure up to max.	220 mbar
granulate consumption	10l granulate – approx. 80 m ²
noise level	75 db
tare weight	approx. 41 kg
measure (incl.trolley)	
width	0,61 m
depth	0,62 m
height	1,30 m
hose package	4,5 m
cable length	7 m
set up	approx. 3 min
disassembly	approx. 5 min (incl. cleaning)

EU-Declaration of Conformity

In compliance with EG-directive for machines 2006/42//EG

systemco GmbH
Herbartstraße 28
D - 14057 Berlin

We hereby declare that the machine / system being produced

Type: Jet machine
 Model: USC 04
 Designation: **TORNADO ACS**

matches in this version with the product being examined on conformity by TÜV Rheinland/Berlin-Brandenburg. Moreover it is conforming to the following EG guidelines and harmonized standards:

2006/42/EG	machine guideline
2004/108/EG	EMV-guideline
2006/95/EWG	low-voltage guideline
DIN EN 296-1;-2	DIN EN 294 DIN EN 349 DIN EN 418 DIN EN 60204-1

Furthermore the application of appropriate national standards and specifications is confirmed.

The technical documentation is completely available.

The appropriate operating instructions are present.

Person responsible for documentation: Uwe Dyballa Tel.: +49 30 3270 – 2157

Berlin, 06.01.2017



Dipl. -Ing. Uwe Dyballa
 CEO