



powered by  Cold Jet.

# *Evolution Line*

---

*Xtreme 40*  
*Elite 20*



---

# Manual

Original Instructions - Revised December 2018



Cold Jet, LLC  
455 Wards Corner Road  
Loveland, Ohio 45140  
USA

Copyright © 2018 by Cold Jet, LLC  
All rights reserved.

---

# CONTENTS

GENERAL INFORMATION .....	6
Dry And Thermal Cleaning Process .....	6
No Residual Blasting Media .....	6
DRY ICE BLASTING: HOW IT OPERATES .....	6
Dry Ice Pellets .....	6
Method .....	6
Cleaning Effect .....	7
SAFETY REGULATIONS .....	7
General .....	7
Personnel Qualifications .....	7
Safety and Risk .....	7
Precautions during Blasting .....	8
Static Electricity .....	8
PACEMAKER Precautions .....	8
Explosive Hazard .....	8
Danger of Congelation .....	9
Danger of Thrown Loose Objects .....	9
Noise .....	9
Dust .....	9
Protective Clothing .....	9
CO <sub>2</sub> Detector .....	10
CO <sub>2</sub> Concentrations .....	10
Low CO <sub>2</sub> .....	10
MACHINE ILLUSTRATIONS .....	11
LABELS ON THE MACHINE .....	13
Identification Plate .....	13
CONTROL PANEL .....	14

WARNING SIGNS LABEL.....	14
BLASTING HOSE .....	15
ICEGUN EVOLUTION LINE W/ LIGHT .....	15
STARTING THE DRY ICE MACHINE.....	16
Setting Up .....	16
Starting.....	17
SHUTTING DOWN THE DRY ICE BLASTING MACHINE .....	20
EMERGENCY STOP .....	20
PRECAUTIONS: BLASTING HOSE.....	21
Connection and Disconnection.....	21
Defective Blasting Hose.....	21
Blasting Hose Repair .....	22
PRECAUTIONS: ELECTRIC CONNECTION .....	22
Main Power Supply.....	22
OFF Button .....	22
Cover Plate at the hopper Bottom .....	22
MAINTENANCE.....	23
Daily before Starting the Machine .....	23
After 100 Hours of Operation .....	23
After 500 Hours of Operation .....	23
REPAIR AND WARRANTY .....	24
Repair .....	24
Terms of Warranty.....	24
NOZZLE SELECTION AND AIR CONSUMPTION .....	25
Nozzle Diameter and Blast Pattern .....	25
Small Blast Pattern.....	25
Wide Blast Pattern.....	25
Nozzle Size.....	25
Air Consumption Table .....	25

Example of Use of the Table ..... 25

TROUBLESHOOTING ..... 29

LONG LIFE SPLITTERNETS ..... 30

    Correct use ..... 30

    Survey: Dosing Disk Types ..... 31

NOTES ..... 35

CONTACT INFORMATION ..... 36

## GENERAL INFORMATION

The Evolution Line manual is for the Elite 20 and the Xtreme 40 dry ice blasting machines produced by IceTech. IceTech machines and accessories have been developed to supply cleaning equipment which minimizes consequential cleaning costs and combines the best characteristics of sand blasting and steam cleaning.

### DRY AND THERMAL CLEANING PROCESS

Dry ice blasting provides a **dry** cleaning process (similar to sand blasting), **AND** a **thermal** cleaning process (familiar in steam cleaning). The blasting media itself (dry ice pellets) sublimates; this means that in most cases the process can be used for cleaning components, machinery and plant equipment without dismantling and often without having to cover adjacent plant equipment.

### NO RESIDUAL BLASTING MEDIA

Dry ice blasting provides a dry and gentle, but extremely efficient, cleaning process that leaves no residual blasting media to be disposed of, and no undesired substances that might penetrate into or be deposited on machines and plant components. This means that cleaning by dry ice blasting becomes an excellent alternative to cleaning with traditional methods.

## DRY ICE BLASTING: HOW IT OPERATES

### DRY ICE PELLETS

The dry ice blasting machine uses small CO<sub>2</sub> "particles" as the blasting medium, called dry ice pellets [CO<sub>2</sub> - the chemical symbol for carbon dioxide]. In a machine commonly known as a pelletizer, liquid CO<sub>2</sub> is used to produce hard and uniform dry ice pellets. The pellets are approx. 3 mm [0.1 inch] in diameter and approx. 10 mm [0.4 inch] in length - or rice-sized. These dry ice pellets have a temperature of -79°C/-110°F. When used for dry ice blasting, the pellets are blasted onto the object to be cleaned at a very high velocity. On contact with the surface of the object, they immediately change from a solid to a gaseous form as they heat up on impact. This change from a solid to a gaseous form, the accompanying tremendous expansion in volume, the high kinetic energy and the low temperatures are the most important factors which result in the loosening of impurities.

### METHOD

The dry ice blasting machine contains a dry ice pellet tank and a dosing unit, which doses the dry ice pellets into the jet of compressed air. By means of the compressed air, the dry ice is transported through a special blasting hose to the blasting gun and nozzle. In the blasting gun, the air stream is accelerated, and the dry ice pellets leave the nozzle of the blasting gun at very high velocity.

## CLEANING EFFECT

The cleaning effect of dry ice blasting is based on three principles:

- **Thermal Effect:**

The dry ice pellets have a temperature of  $-79^{\circ}\text{C}/-110^{\circ}\text{F}$ , and impurities are therefore cooled down drastically; the impurities shrink and loosen due to different thermal expansion coefficients.

- **Kinetic Effect:**

When the dry ice pellets leave the blasting gun nozzle they have high kinetic energy and strike the impurities at a speed almost equivalent to the velocity of sound.

- **Sublimation Effect / Volume Expansion:**

The dry ice pellets are being pressed into the brittle impurities and sublimate immediately on contact. The resulting volume increase by a factor of approx. 700 contributes to tearing away the contaminant.

## SAFETY REGULATIONS

### GENERAL

This manual contains instructions and safety regulations which must be followed while starting, operating and maintaining the dry ice blasting machine. It is important that the manual is kept, so the operator always knows its exact location. It is also important the owner makes certain that the operator reads, understands and follows the contents of the manual.

### PERSONNEL QUALIFICATIONS

Personnel responsible for operation, servicing and maintenance must be suitably qualified to perform these functions. Special training in machine handling as well as in repair and maintenance is offered by the manufacturer of the machine. The owner of the machine must ensure that the person appointed to operate the dry ice blasting machine fully understands and is able to follow the **SAFETY REGULATIONS** defined in the following pages, and the **WARNING SYMBOLS** located on the machine.

### SAFETY AND RISK

The machine is constructed to comply with the standards and clauses contained in the Declaration of Conformity and the terms of sale. Therefore, provided the manufacturer's instructions are followed, the machine will not pose any risk to the operator.



## PRECAUTIONS DURING BLASTING

Air, CO<sub>2</sub> gas and dry ice pellets leave the gun nozzle at a very high velocity (up to 300 m/s - 984 ft/s).

Therefore:

- do not aim the nozzle at a person[s] or in the direction of a place[s] where other people work,
- remember, dry ice pellets can be deflected back from the object being cleaned,
- do not aim the nozzle in directions where damage might result. Do not use the machine "for fun" and under no circumstances should you aim the gun nozzle at persons or other living creatures.



## STATIC ELECTRICITY

Serious discharge of static electricity can occur. Always make sure that objects to be cleaned are adequately earthed/grounded and that this earthing/grounding remains stable throughout the whole cleaning process. The dry ice blasting machine is earthed/grounded, from machine cabinet to blasting gun, and through the main electricity connection on the rear side of the machine - provided that the machine has been set up and connected as described under "Starting the Dry Ice Machine" on page 16.

## PACEMAKER PRECAUTIONS

Do NOT use the dry ice blasting machine if you are wearing a pacemaker. The dry ice blasting machine may cause pacemaker malfunction.

## EXPLOSIVE HAZARD

The machine must never be used in surroundings where there is a danger of explosion. Despite optimum earthing/grounding of both machine and cleaning object, static electricity can be generated and create a spark.





### **DANGER OF CONGELATION**

At atmospheric pressure, CO<sub>2</sub> in a solid form has a temperature of -79°C/-110°F or lower and can give rise to congelation when the dry ice comes in contact with unprotected skin.



### **DANGER OF THROWN LOOSE OBJECTS**

There is a risk of dry ice pellets and small objects being deflected back during blasting. Therefore small objects must be firmly secured before blasting. Loose objects must not be left in the area where the cleaning process is taking place! The operator must always wear approved protective goggles or a protective shield when working with the dry ice blasting machine. This also applies to anybody near the workspace.



### **NOISE**

Because of the high air velocities in the gun nozzle during dry ice blasting, the level of noise in the area where the operator works may exceed the maximum permissible level. The owner is responsible for keeping himself acquainted with, and informing the operator of any precautions to be taken as to the application of ear protection, since legislation on maximum permissible noise levels varies from one country to another.



### **DUST**

Certain types of dust have a tendency to accumulate during the cleaning process. Therefore we recommend that the operator wears a dust mask or if necessary a breathing mask and industrial protective clothing.



### **PROTECTIVE CLOTHING**

When using the dry ice blasting machine, the operator must wear long-sleeved industrial protective clothing and gloves in order to eliminate the risk of congelation when the dry ice comes in contact with unprotected skin.

Read the safety data sheet provided by the dry ice supplier and follow the instructions given.



### CO<sub>2</sub> DETECTOR

The presence of a CO<sub>2</sub> detector is recommended in areas of limited ventilation such as rooms, closed tanks, etc. The CO<sub>2</sub> detector can be installed to interrupt the blasting process before the CO<sub>2</sub> concentration exceeds a prescribed limit.



### CO<sub>2</sub> CONCENTRATIONS

Dry ice pellets are CO<sub>2</sub> in a solid form. At normal atmospheric pressure, CO<sub>2</sub> can only exist in a solid form at a temperature of -79°C/-110°F or lower.

When CO<sub>2</sub> is used as a blasting medium, it becomes heated and changes into a gaseous form. As CO<sub>2</sub> has a higher specific gravity than ordinary atmospheric air, inhaled air will contain CO<sub>2</sub> - especially if the blasting process takes place in small or partly closed rooms.

In such conditions there is a risk of the oxygen content of inhaled air being replaced by CO<sub>2</sub>. Therefore it is essential to make sure the room is well ventilated when dry ice blasting!

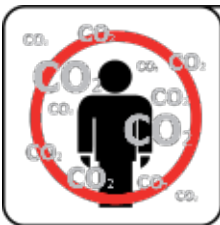

### LOW CO<sub>2</sub>

- low CO<sub>2</sub> concentrations [3-5%] result in headaches and rapid breathing,
- CO<sub>2</sub> concentrations of 7-10% produce headaches and nausea, and may lead to unconsciousness,
- higher CO<sub>2</sub> concentrations lead to unconsciousness and in the worst case - suffocation.

As stated above, high CO<sub>2</sub> concentrations can displace oxygen and result in unconsciousness. Therefore, avoid using the dry ice blasting machine in spaces/rooms where ventilation is limited.

## MACHINE ILLUSTRATIONS



1. Hopper lid - opens from the side.
2. Handle for maneuvering the machine.
3. Control panel.
4. Connection for blasting hose.
5. Signal cable from blasting hose. Transfer signal from the trigger switch on the blasting gun to the machine control.
6. Extra grounding cable - prevents static build up.
7. Front bumper.

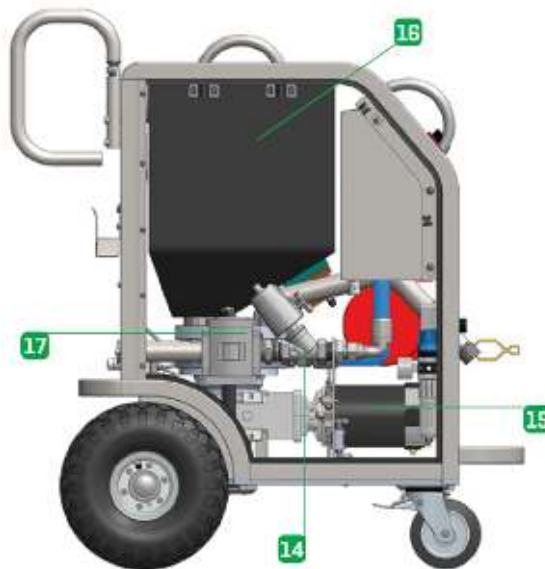
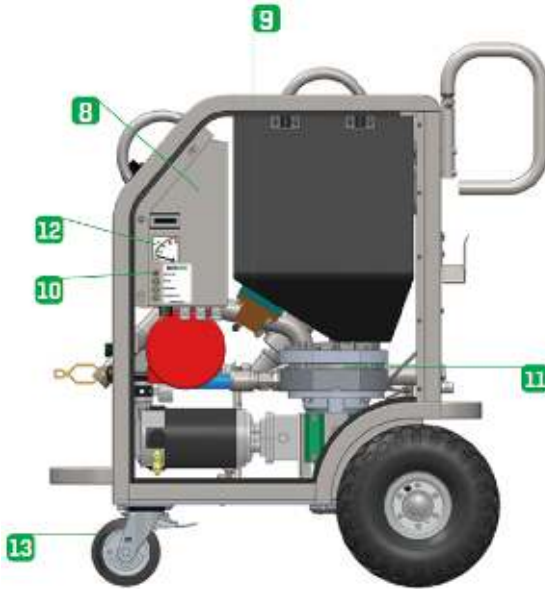

8. Control box.
9. Pneumatic vibrator ensures continuous pellet flow.
10. LED indicators which display operating mode.
11. Quick change dosing disc - doses dry ice into the blasting air stream.
12. Ammeter - indicates working status of the dosing disc.
13. Machine wheel brakes - must remain applied when the machine is in operation.
14. Main valve for blasting air stream. If the machine is ready for operation and the blasting parameters required have been set, this valve opens for the blasting air stream, every time the trigger switch on the blasting gun is activated. As soon as the trigger switch on the blasting gun is released, the valve cuts off the air stream.
15. 24 V DC motor - independent on the power source.
16. Insulated dry ice hopper.
17. Pressure control - indicates the blasting pressure value set on the control panel.



*Elite 20*



*Xtreme 40*



- 18. Ergonomic, collapsible handles - for easy transportation and hose storage.
- 19. Cable holder.
- 20. Air release valve .
- 21. Compressed air supply.
- 22. Main power supply.
- 23. Warning symbols.

**Important!**

When lifting with a forklift truck, make sure that the forks are inserted all the way under the machine frame itself. When using a crane for lifting, a yoke with straps under the cabinet frame must be used. Ensure that wheels and wheel brakes do not become damaged.

**LABELS ON THE MACHINE**

**IDENTIFICATION PLATE**

<b>Elite 20 ½"</b>		<b>ICE TECH</b>	
Machine no.:	Weight:	104 kg / 218 lbs	
Serial no.:	Year:	Power: 100-240V AC 50/60 Hz 8/4 A	
Pmax.:		Max. 16 Bar / 232 psi	
		 	
Industrivej 62 - DK-6740 Bramming - Phone +45 7656 1500			

<b>Xtreme 40 ¼"</b>		<b>ICE TECH</b>	
Machine no.:	Weight:	117 kg / 229 lbs	
Serial no.:	Year:	Power: 100-240V AC 50/60 Hz 8/4 A	
Pmax.:		Max. 16 Bar / 232 psi	
		 	
Industrivej 62 - DK-6740 Bramming - Phone +45 7656 1500			

## WARNING SIGNS LABEL

						
NEVER AIM THE BLASTING GUN AT PERSONS!	DANGER OF SUFFOCATION!	DANGER OF ELECTROSTATIC DISCHARGE!	DANGER OF CONGELATION! DRY ICE TEMP: -78°C / -110°F	WEAR PROTECTIVE GLOVES AND LONG-SLEEVED INDUSTRIAL PROTECTIVE CLOTHING!	WEAR EAR AND EYE PROTECTION / FACE SHIELD!	WEAR A DUST MASK!
DIE STRAHLPISTOLE NIE AUF PERSONEN RICHTEN!	ERSTICHUNGSBEFAHR!	GEFAHR VOR ELEKTROSTATISCHER ENTLADUNG!	GEFAHR VOR ERFRIERUNGEN! TROCKENEISTEMP: -78°C	SCHUTZHANDSCHUHE UND INDUSTRIESCHUTTKLEIDUNG MIT LANGEN ÄRMELN TRAGEN!	GEHÖRSCHUTZ UND SCHUTZBRILLE / GESICHTSSCHUTZSCHILD TRAGEN!	STAUBMASKE TRAGEN!
INTERDICTION DE DIRIGER LE PISTOLET VERS!	RISQUES D'ÉTOUFFEMENT!	RISQUES DE DÉCHARGES ÉLECTROSTATIQUES	RISQUES DE GELURE, LA TEMPÉRATURE DE LA NEIGE CARBONIQUE EST DE -78°C	PORTER UN GILET DE TRAVAIL, À MANCHES LONGUES!	UTILISER UN MASQUE DE PROTECTION POUR LES YEUX ET UN CASQUE POUR LES OREILLES!	PORTER UN MASQUE ANTI-POUSSIÈRE!
NO PROYECTAR HACIA OTRAS PERSONAS!	RIESGO DE ASFIXIA!	RIESGO DE SUFRIR DESCARGAS ELECTROSTÁTICAS	RIESGO DE QUEMADURAS TEMPERATURA DEL HIELO SECO DE -78°C	UTILIZAR VESTIMENTA DE TRABAJO CON MANGAS LARGAS!	UTILIZAR MASCARILLA, PROTECCION DE OJOS Y OÍDOS!	UTILIZAR MASCARILLA ANTIPOLVO!

## CONTROL PANEL

- Machine ON / OFF.
- Empty hopper function [\*available only for Xtreme 40] - easily removes dry ice residue from the hopper.
- Light button - turns on light in the gun.
- LED light display - monitoring for air, dry ice flow and gun light status.
- Emergency stop.
- Air supply pressure indicator.
- Blasting pressure indicator.
- Dry ice consumption adjustment.
- Air pressure control.
- Table with the consumption of dry ice in kg/h -lb/min.

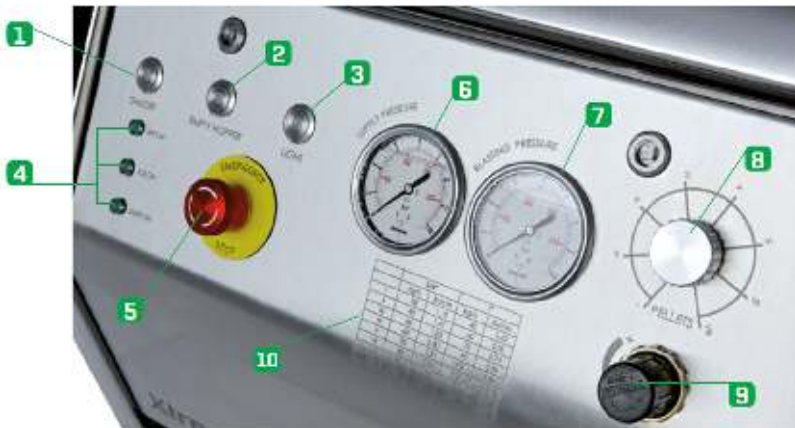

## BLASTING HOSE



1. Hose coupling - for connection on front of the dry ice blasting machine.
2. Signal cable - for connection on front of the dry ice blasting machine.
3. Signal cable - for connection to the blasting gun.
4. Hose coupling - for connection to the blasting gun.

IceTech offers three different types of blasting hoses: HD hoses, fiber reinforced silicon hoses and Teflon hoses.

## ICEGUN EVOLUTION LINE W/ LIGHT



1. Light.
2. Safety switch.
3. Two-step trigger: (Blasting with dry ice AND air, - Blasting with AIR ONLY).
4. Signal cable.
5. Standard Round Nozzle - interchangeable.
6. Nozzle adapter.

**Dim. (mm/inch) without nozzle:**

**Length:** 270 / 10.63

**Width:** 60 / 2.36

**Height:** 225 / 8.86

**Weight without nozzle:**

**g:** 1100 / **lb:** 2.42

## STARTING THE DRY ICE MACHINE

### SETTING UP



1. Make sure the machine is on a level, horizontal surface, and that the wheel brakes are applied.

2. Plug the blasting hose couplings into the socket on the front of the machine and the blasting gun, respectively. Check to make sure the hose couplings are correctly connected.



3. Connect the signal cable at both ends of the blasting hose with the sockets on the front of the machine and the blasting gun.



#### **CORRECT ORDER IS IMPORTANT!**

**FIRST** connect the blasting hose couplings,  
**THEN** the signal cable.

4. Connect the main power supply.







5. Connect the compressed air supply.

## STARTING

When the machine has been set up as described above (points 1-5), the following procedure shall be followed before the cleaning process has begun:

6. Check carefully to ensure that the dosing unit is dry and clean at the hopper outlet.



7. Open the external compressed air supply [slowly].

8. The Evolution Line machine is equipped with a Static Ground Cable which is mounted on the front of the machine. Connect the Static Ground Cable to the item being blast cleaned or to an electrically conductive supporting structure of the material.





9. Check to make sure that the machine is in the normal operating position [the emergency stop button is pulled out].

10. Turn the machine ON [press the ON/OFF button].



11. Lift the lock pin and activate the trigger on the blasting gun for a few seconds to allow air to flow through the system. This checks for moisture in the airstream and proper operation of the dosing disc, vibrator, and regulator.

12. Fill dry ice pellets into the hopper [this can be done while the machine is in operation].



**Please note:** It is recommended that you run the hopper empty before each filling to enable the operator to see whether “snow” or lumps appear in the dry ice. These can prevent a continuous supply of dry ice to the dosing unit.

**Never leave the machine with the lid open.**



13. Adjust the dry ice consumption [kg/h / lb/min.] and the blasting pressure [bar/psi] - the value is shown on the pressure gauge.

14. Start dry ice blasting.



NB Please note: Before activating the blasting gun switch, the operator must be in a safe and stable working position. Depending on the jet pressure, the recoil on the jet gun also changes. At the highest jet pressure with the largest nozzle diameter, the recoil force can amount to 10 kg / 22 lbs, which is why it is ensured that the operator does not lose balance.



15. "Light button" (only when machine is equipped with a light gun) - to improve visibility during blasting turn on the "Light button" on the control panel.

16. "Empty hopper function" [\*available only for Xtreme 40] - if there are residues of dry ice in the hopper, push the button for 3 sec. to start the empty hopper cycle.



17. "Empty hopper function" [\*available only for Xtreme 40] can also be used in an emergency situation when a foreign object enter the dosing unit. By pressing the button for 1-2 seconds you can move the dosing disc counter-clockwise by a small degree which will allow for the removal of the object.

## SHUTTING DOWN THE DRY ICE BLASTING MACHINE

When the cleaning task has been completed, the following procedure must be carried out before the machine is dismantled or stored:

- Empty the hopper.
- Activate the trigger on the blasting gun for a few seconds in order to empty the system of possible dry ice residue.
- Close the compressed air supply.
- Activate the trigger on the blasting gun for a few seconds in order to depressurize the system or use the air release valve.
- Turn off the machine (press the ON/OFF button).
- Disconnect the main power supply.
- Open the air release valve to depressure the air side supply.
- Disconnect the compressed air supply.
- It is recommended to disconnect the blasting hose.



### **CORRECT ORDER IS IMPORTANT!**

**FIRST** disconnect the signal cable,  
**THEN** the blasting hose couplings.

- Avoid kinking the blasting hose, when rolling it up.

## EMERGENCY STOP

Activation of the emergency stop button immediately stops the blasting air stream and the dry ice flow. Before the machine can be restarted, the following procedure must be carried out:

- Disengage the emergency stop button (twist and release the button).
- Start the machine (press the ON/OFF button).
- Restart the blasting air stream by activating the trigger switch on the blasting gun.

# PRECAUTIONS: BLASTING HOSE

## CONNECTION AND DISCONNECTION

**Never disconnect the blasting hose** from the machine or blasting gun when the main power supply and/or compressed air supply are connected. Otherwise activation of the trigger on the blasting gun will result in a discharge of blasting air through an open outlet instead of through the blasting gun nozzle. If this happens, the operator will lose control of the air stream, and serious injury that could result in death.



**CORRECT ORDER FOR CONNECTION:**

**FIRST** connect the blasting hose couplings,  
**THEN** the signal cable.



**CORRECT ORDER FOR DISCONNECTION:**

**FIRST** disconnect the signal cable,  
**THEN** the blasting hose couplings.

## DEFECTIVE BLASTING HOSE

The outer hose sleeve protects the operator from any exposure caused by wear and tear of the inner hose. No pressure build-up is permissible in the outer sleeve during operation. If a **defective blasting hose** is used, the operator risks serious injury from being hit by dry ice pellets. Any sign of **inflation** means that the inner hose is in some way defective.

**NOTE:** If that fault occurs, stop the machine IMMEDIATELY:

- Close the compressed air supply immediately.
- Activate the trigger on the blasting gun until the system is depressurized or use the air release valve.
- Activate the emergency stop button.
- Disconnect the main power supply.
- Disconnect the compressed air supply.
- Disconnect the blasting hose (**FIRST** disconnect the signal cable, **THEN** the blasting hose couplings).
- Make sure the blasting hose is repaired and pressure-tested (next page).
- Although the hopper may not be empty, the system must not be blasted through until a new/repared blasting hose has been connected.

## BLASTING HOSE REPAIR

Blasting hoses must only be repaired either by an IceTech technician or by the owner's qualified personnel having been trained by IceTech in the repair and maintenance of IceTech dry ice blasting machines and accessories. Beyond the necessary knowledge, the person concerned must have appropriate tools and equipment, as well as the auxiliary materials required, at his disposal.



The operator must **NEVER** repair the blasting hose without using original IceTech spare parts!

IceTech offers three different types of blasting hoses: HD hoses, fiber reinforced silicon hoses and Teflon hoses.

## PRECAUTIONS: ELECTRIC CONNECTION

### MAIN POWER SUPPLY

The main electric connection supplies the machine with LN + PE. (L-N), respecting the live/phase (L), neutral (N) and ground (PE) connections. The machine voltage is specified on the rating plate. The control circuits use 24 V DC.

### OFF BUTTON

The OFF button cuts off voltage to the control circuits, but does not make the machine voltage-free.



The machine is only voltage-free when the main power supply has been disconnected.

### COVER PLATE AT THE HOPPER BOTTOM

A cover plate is fitted at the bottom of the hopper to prevent the operator from coming into contact with the moving parts of the dosing unit during operation. Since the cover plate is part of the safety precautions of the machine, it must NOT be removed.

## MAINTENANCE

### DAILY BEFORE STARTING THE MACHINE

1. Pay special attention to places on the blasting hose where kinks may have occurred during operation.
2. If any kind of damage to the blasting hose or the machine itself is noted, such damage must be repaired either by an IceTech technician or by the owner's qualified personnel who has been trained by IceTech in the repair and maintenance of IceTech dry ice blasting machines and accessories. Beyond the necessary knowledge, the person concerned must have appropriate tools and equipment, as well as the auxiliary materials required, at his disposal.
3. Check the current on the Ammeter when you pull the trigger. If the average current is over 30 amperes, a service check of the dosing unit is recommended.
4. In this way it is ensured that the repaired blasting hose/machine continues to comply with the safety regulations after repair.

### AFTER 100 HOURS OF OPERATION

1. Examine connections for wear and tear or other damage. Tighten up or replace them as necessary.
2. Check the dosing unit for damage and leakage.

### AFTER 500 HOURS OF OPERATION

1. Examine connections for wear and tear or other damage. Tighten up or replace them as necessary.
2. Dismantle the dosing unit. Check the dosing disc and wear plates for damage and wear. If the dosing disc and wear plates are OK - then reassemble and readjust the dosing unit. If wear plates and dosing disc are not OK - then ...
3. Replace the dosing disc, and replace the upper and lower wear insert at the dosing disc.
4. Reassemble the dosing unit.
5. Check the current on the Ammeter.
6. Check the blasting hose for wear and tear.

## REPAIR AND WARRANTY

### REPAIR

The repair/replacement of the following parts can be made by the owner's qualified personnel:

- Signal cable plugs on the machine, blasting hose and blasting gun.
- Blasting hose couplings on the machine, hose and gun.
- Electricity and compressed air sockets on the rear of the machine.



When making repairs/replacements, use only original IceTech spare parts.

### TERMS OF WARRANTY

In order for us to provide you the best customer support and notify you of product improvement updates, please fill Warranty Registration Form on our homepage: [www.icetechworld.com](http://www.icetechworld.com).

In order to comply with the terms of the warranty, and for safety reasons, repairs other than those stated above require relevant tools and equipment and therefore must always be made either by an IceTech technician or by the owner's qualified personnel who have been trained by IceTech in the repair and maintenance of IceTech dry ice blasting machines and accessories. Beyond the necessary knowledge, the person concerned must have appropriate tools and equipment, as well as the auxiliary materials required, at his disposal.

The liability of the manufacturer under the terms of the CE and cUL endorsement in regards to safety may become invalid:

- If repairs are made using non-IceTech spare parts.
- If repairs are made by unqualified personnel.
- If repairs are unsatisfactory due to lack of relevant tools and equipment.

In such cases, the liability of the manufacturer will be solely confined to any manufacturing faults/errors made prior to the machine being delivered and before repairs/ replacements have been made.



## NOZZLE SELECTION AND AIR CONSUMPTION

### NOZZLE DIAMETER AND BLAST PATTERN

The nozzle selection should be based on finding the best combination of air consumption, dry ice consumption and cleaning efficiency. The selection of the nozzle spread angle should depend on how strong or weak a cleaning effect is desired for a given dry ice consumption.

#### SMALL BLAST PATTERN

A small blast pattern gives a concentrated jet with a high cleaning effect to a small area.

#### WIDE BLAST PATTERN

A large spread angle [e.g. the flat nozzle] results in a jet which, for the same consumption of dry ice and air, cleans a larger area with a lesser cleaning effect.

### NOZZLE SIZE

It is important to select the size of nozzle which will provide the desired air velocity using the available compressor capacity. Choosing the right nozzle size and type will optimize not only the cleaning effect, but also the dry ice consumption and the time required for the cleaning process itself. Refer to the air consumption table for guidance.

### AIR CONSUMPTION TABLE

The air consumption table indicates the air consumption in relation to nozzle size and blasting pressure. The maximum supply pressure of the Elite 20 and the Xtreme 40 amounts to 16 bar/232 psi.

### EXAMPLE OF USE OF THE TABLE

The air consumption table outlines the air consumption achieved with the nozzle sizes available. If for example a size 8 nozzle is used at a blasting pressure of 6 bar [87 psi] the air consumption amounts to 4.2 N·m<sup>3</sup>/min [148.3 ft<sup>3</sup>/min]. The available compressor capacity will always need to be taken into consideration and therefore it may be necessary to do some test blasts and observe the results until the optimum combination of nozzle size and blasting pressure for a certain application is found.

## AIR CONSUMPTION TABLE

bar >>	2	3	4	5	6	7	8	9	10	11	12	13	14	15	16
Ø5	0.7	0.9	1.2	1.4	1.6	1.9	2.1	2.3	2.6	2.8	3.0	3.3	3.5	3.7	4.0
Ø6	1.0	1.3	1.7	2.0	2.4	2.7	3.0	3.4	3.7	4.0	4.4	4.7	5.1	5.4	5.7
Ø7	1.4	1.8	2.3	2.7	3.2	3.7	4.1	4.7	5.1	5.7	6.2	6.6	7.1	7.4	7.7
Ø8	1.8	2.4	3.0	3.6	4.2	4.8	5.4	6.1	6.7	7.3	7.9	8.4	9.1	9.7	10
Ø9	2.3	3.0	3.8	4.6	5.3	6.1	6.9	7.7	8.4	9.4	10.1	10.8	11.7	12.1	13
Ø10	2.6	3.7	4.7	5.7	6.6	7.6	8.5	9.6	10.4	11.3	12.4	13.4	14.3	15.3	16

Air consumption in N·m<sup>3</sup>/min at the pressures indicated [bar].

Ø=Nozzle Diameter

psi >>	29	44	58	73	87	102	116	131	145	160	174	189	203	218	232
Ø5	25	32	42	49	56	67	74	81	92	99	106	116	124	131	144
Ø6	35	46	60	71	85	95	106	120	131	141	155	166	180	191	201
Ø7	49	64	81	95	113	131	145	166	180	201	219	233	251	261	272
Ø8	64	85	106	127	148	169	191	215	237	258	279	297	321	342	353
Ø9	81	106	134	162	187	215	244	272	297	332	357	381	413	427	459
Ø10	99	131	166	201	233	268	300	339	367	399	438	473	505	459	565

Air consumption in ft<sup>3</sup>/min at the pressures indicated [psi].

Ø=Nozzle Diameter

## TECHNICAL DATA

### Elite 20

Technical Data	Elite 20, ½"	Elite 20, ¾"
<b>Dimensions [mm] / [in]:</b>		
Length:	739.7 / 29	
Width:	450 / 17.7	
Height (including handle):	1080 / 42.5	
<b>Weight:</b>		
kg: / lb:	104 / 230	
<b>Dry Ice Capacity:</b>		
liter: / ft <sup>3</sup> :	20 / 0.71	
<b>Dry Ice Consumption:</b>		
kg/hr:	15 - 60	30 - 100
lb/min:	0.5 - 2.2	1.1 - 3.7
<b>Supply Pressure:</b>		
bar:	min 5 - max 16	
psi:	min 72 - max 232	
<b>Blasting Pressure:</b>		
bar:	min 2 - max 10	min 2 - max 16
psi:	min 29 - max 145	min 29 - max 232
<b>Air Consumption:</b>		
N·m <sup>3</sup> /min:	0.7 - 3.7	0.7 - 10
cfm:	25 - 130	25 - 353
(depending on nozzle combination)		
<b>Compressed Air Connection:</b>	¾" claw coupling	1" claw coupling
<b>Air Quality:</b>	According to ISO 8573-1 Class 3 for environment temperature below + 5°C / 41°F	
<b>Power Consumption:</b>	500W, 100V - 240V AC 50/60 Hz +PE (GND)	
<b>Blasting Hose:</b>	½" Single Hose System	¾" Single Hose System
<b>Noise:</b>	Noise level up to 120 dB[A]. Depending on blasting pressure, nozzle combination and material surface.	

## TECHNICAL DATA

### Xtreme 40

Technical Data	Elite 20, ½"	Elite 20, ¾"
<b>Dimensions [mm] / [in]:</b>		
Length:	795 / 31.3	
Width:	534 / 21	
Height (including handle):	990 / 38.9	
<b>Weight:</b>		
kg: / lb:	117 / 257	
<b>Dry Ice Capacity:</b>		
liter: / ft <sup>3</sup> :	40 / 1.41	
<b>Dry Ice Consumption:</b>		
kg/hr:	30 - 100	45 - 150 (65 - 220 opt.)
lb/min:	1.1 - 3.7	1.7 - 5.5 (2.4 - 8.1 opt.)
<b>Supply Pressure:</b>		
bar:	min 5 - max 16	
psi:	min 72 - max 232	
<b>Blasting Pressure:</b>		
bar:	min 2 - max 16	
psi:	min 29 - max 232	
<b>Air Consumption:</b>		
N·m <sup>3</sup> /min:	0.7 - 10	1.4 - 16
cfm:	25 - 353	35 - 565
(depending on nozzle combination)		
<b>Compressed Air Connection:</b>	1" claw coupling [optional 1.5" claw coupling]	
<b>Air Quality:</b>	According to ISO 8573-1 Class 3 for environment temperature below + 5°C / 41°F	
<b>Power Consumption:</b>	500W, 100V - 240V AC 50/60 Hz +PE (GND)	
<b>Blasting Hose:</b>	¾" Single Hose System	1" Single Hose System
<b>Noise:</b>	Noise level up to 120 dB(A). Depending on blasting pressure, nozzle combination and material surface.	
<b>Features:</b>	Empty hopper function	

## TROUBLESHOOTING

Problem Description	Possible Reason and Solution
<p>Machine is not turning on after pushing ON/OFF</p>	<p><b>Check if “Main Supply” LED is on, if not:</b></p> <ul style="list-style-type: none"> <li>• Check power supply source</li> <li>• Check circuit breaker F11 is in red position</li> <li>• Check fuse F212 , and if necessary replace</li> </ul> <p><b>Check if “24 VDC LED” is on, If not:</b></p> <ul style="list-style-type: none"> <li>• Check fuse F203 &amp; F214, if necessary replace</li> <li>• Push and release emergency stop, followed by turning the machine Off and On</li> </ul> <p><b>For further support call service.</b></p>
<p>Air is not flowing</p>	<p><b>Verify compressed air supply is on and at minimum 72 psi / 5 bar or above.</b></p> <p><b>Verify blasting pressure is regulated above 0 psi / bar.</b></p> <p><b>Check ‘Air On’ LED is on when trigger is pulled, if not:</b></p> <ul style="list-style-type: none"> <li>• Check signal cable connections</li> </ul> <p><b>For further support call service.</b></p>
<p>Dosing unit is not working / ice is not flowing</p>	<p><b>Check ‘Motor Driver’ LED is on, if not:</b></p> <ul style="list-style-type: none"> <li>• Check fuse F203, and if necessary, replace</li> </ul> <p><b>Check ‘Ice On’ LED is on when trigger is pulled, if not:</b></p> <ul style="list-style-type: none"> <li>• Check signal cable connections</li> </ul> <p><b>Check ammeter range is less than 30 or not in the red, if so:</b></p> <ul style="list-style-type: none"> <li>• Check hopper/dosing disc for foreign objects</li> <li>• Dosing disk may be frozen. Call service for thawing procedures</li> </ul> <p><b>For further support call service.</b></p>
<p>Light on the gun is not working</p>	<p><b>Check that ‘Light On’ LED is on, if not:</b></p> <ul style="list-style-type: none"> <li>• Check ‘Light’ button is activated. Light is activated by trigger function. Light is set to turn off 30 seconds after trigger is released.</li> </ul> <p><b>Check signal cable connections.</b></p> <p><b>For further support call service.</b></p>
<p>Empty hopper function is not working (Xtreme 40 model only)</p>	<p><b>To activate empty hopper function press and hold ‘Empty Hopper’ button for a minimum of 5 seconds. The empty hopper function will automatically deactivate after 30 seconds.</b></p> <ul style="list-style-type: none"> <li>• Check hopper/dosing disc for foreign objects</li> <li>• Dosing disk may be frozen. Call service for thawing procedures</li> </ul> <p><b>For further support call service.</b></p>

# LONG LIFE SPLITTERNETS

## CORRECT USE

Splitternet mm	1.5		2		2.5		3	
	Max Ice kg/h	Min. Air	Max Ice kg/h	Min. Air	Max Ice kg/h	Min. Air	Max Ice kg/h	Min. Air
Ø5	20	4	25	4	30	4	35	4
Ø6	25	4	30	4	35	3.5	40	3.5
Ø7	30	3	35	3	40	3	45	3
Ø8	35	3	40	3	45	3	50	3
Ø9	50	3	70	3	100	2	120	2
Ø10	60	2	80	2	120	2	150	2

### High and Low IceSplitters

- Pulverizes dry ice pellets
- Light-weight aluminum
- To be used when very low abrasion is required, cleaning sensitive objects like electrical switchboards, printed circuits, etc.

### Splitter Discs

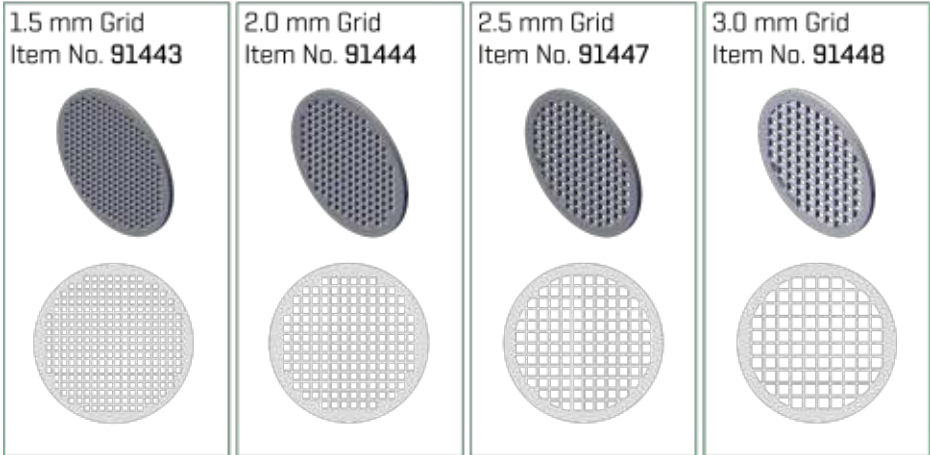

### Splitternet

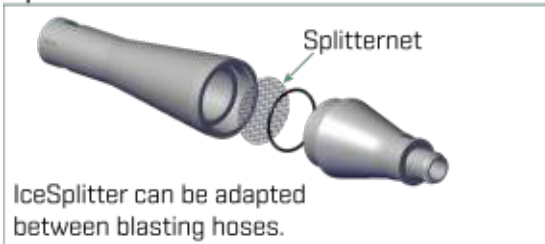

### IceSplitter Adapters



## SURVEY: DOSING DISK TYPES

Splitternet mm	1.5	2	2.5	3	
0V	30 kg/h	45 kg/h	65 kg/h	15 kg/h	0 bar
1V	37 kg/h	55.5 kg/h	80.5 kg/h	19 kg/h	1.6 bar
2V	44 kg/h	66 kg/h	96 kg/h	23 kg/h	3.2 bar
3V	51 kg/h	76.5 kg/h	111.5 kg/h	27 kg/h	4.8 bar
4V	58 kg/h	87 kg/h	127 kg/h	31 kg/h	6.4 bar
5V	65 kg/h	97.5 kg/h	142.5 kg/h	35 kg/h	8.0 bar
6V	72 kg/h	108 kg/h	158 kg/h	39 kg/h	9.6 bar
7V	79 kg/h	118.5 kg/h	173.5 kg/h	43 kg/h	11.2 bar
8V	86 kg/h	129 kg/h	189 kg/h	47 kg/h	12.8 bar
9V	93 kg/h	139.5 kg/h	204.5 kg/h	51 kg/h	14.4 bar
10V	100 kg/h	150 kg/h	220 kg/h	55 kg/h	16.0 bar

### Dosing Discs

Disc 1  
Item No. 95100

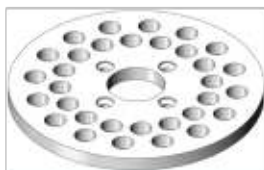

Disc 2  
Item No. 500587



Disc 3  
Item No. 500586



Disc 4  
Item No. 95111





powered by  Cold Jet



**We as the manufacturer:**

Cold Jet, LLC  
455 Wards Corner Road  
Loveland, OH 45140 USA

**Hereby declares that the following product:**

Product Designation: Xtreme 40  
Type/Serial no.:

**Is in compliance with the following European directives:**

Directive 2006/42/EC [Machinery Directive]  
Directive 2014/30/EU [EMC Directive]  
Directive 2014/35/EU [Low Voltage Directive]

**Harmonized standards applied:**

EN ISO 12100:2010	EN ISO 4414:2010	EN ISO 13857:2008
EN ISO 14120:2016-03	EN ISO 13732-3:2008	EN 60204-1:2006/AC:2010
EN ISO 14119:2014-03	EN ISO 13849-1:2015	

**Person in the European Community authorized to compile the technical documentation:**

Cold Jet Sp.zo.o, Product Development Manager Maciej Doczekala, Lukowska 12, Oborniki 64-600, Poland

**Place and Date of Issue:** Loveland, US on June 7, 2018



Arvid Nielsen  
Head of Technology & Engineering, VP

Compliant with Directive 2006/42/EC Annex II A





## CONTACT INFORMATION

Find the customer support and technical services contact information for your region in the table below.

<p><b>USA - Cold Jet, LLC</b> (World Headquarters) 455 Wards Corner Road Loveland, Ohio 45140</p>	<p>24-Hour Customer Support Phone [US]: +1-800-777-9101 Phone [Outside US]: +1 [513] 576-8981 Email: <a href="mailto:service@coldjet.com">service@coldjet.com</a> Website: <a href="http://www.coldjet.com">www.coldjet.com</a></p>
<p><b>Canada - Cold Jet Canada</b> 1727 Industrial Road, Unit 1 Cambridge, Ontario N3H 5G7</p>	<p>Phone: +1-800-337-9423 Ext. 501 After Hours Support: +1-800-777-9101 Email: <a href="mailto:service@coldjet.com">service@coldjet.com</a></p>
<p><b>Latin America - Cold Jet Latinoamérica</b> San Alberto 404 P2 Col. Residencial Santa Barbara San Pedro Garza Garcia, Nuevo Leon Mexico 66226</p>	<p>Phone: +52 (81) 1097-0445 After Hours Support: +1 [513] 576-8981 Email: <a href="mailto:service@coldjet.com">service@coldjet.com</a></p>
<p><b>Belgium - Cold Jet Europe bvba</b> (European Headquarters) Zone 1 Researchpark 330 B-1731 Zellik</p>	<p>Phone: +32 (0) 13 53 95 47 After Hours Support: +1 [513] 576-8981 Email: <a href="mailto:service.eu@coldjet.com">service.eu@coldjet.com</a></p>
<p><b>Germany - Cold Jet Deutschland GmbH</b> Obere Industrie Strasse 1 54595 Weinsheim</p>	<p>Phone: +49 (0) 6551 9606-0 After Hours Support: +1 [513] 576-8981 Email: <a href="mailto:service.eu@coldjet.com">service.eu@coldjet.com</a></p>
<p><b>Spain - Cold Jet Madrid</b> Edificio Foro de Somosaguas, Planta 2 Oficina 14 Pinar de Somosaguas 89 Bis 28223 Pozuelo de Alarcón</p>	<p>Phone: +34 91 426 79 63 After Hours Support: +1 [513] 576-8981 Email: <a href="mailto:service.eu@coldjet.com">service.eu@coldjet.com</a></p>
<p><b>China</b> Room 113, Building 2 Huguang East Road No. 89 Minhang, Shanghai 201108</p>	<p>Phone: +86 21 5296 7161 After Hours Support: +1 [513] 576-8981 Email: <a href="mailto:service@coldjet.com">service@coldjet.com</a></p>
<p><b>Japan/Korea</b> 1-20-4 Ishiwaru, Sumida Tokyo 130-0011</p>	<p>Phone: +811 6869 2665 After Hours Support: +1 [513] 576-8981 Email: <a href="mailto:service.eu@coldjet.com">service.eu@coldjet.com</a></p>

[www.coldjet.com](http://www.coldjet.com)