

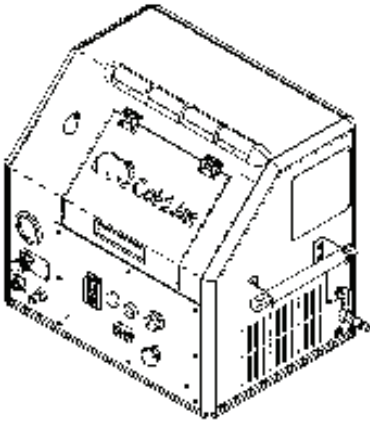

MICROCLEAN[®]

OPERATOR MANUAL

i³ MicroClean Dry Ice Blast System



SAFETY

General Safety Precautions.....	6
Electrostatic Discharge.....	7
Carbon Dioxide	7

COMPONENT GUIDE

Front View	10
Left/Right View.....	11
Blast Applicator	12
Standard Carts.....	13

OPERATION

Start Up.....	16
Shut Down.....	16
Blasting.....	17
Blasting Technique	17

MAINTENANCE

Maintenance	20
Troubleshooting.....	21

APPENDIX

Specifications	24
Blast Air Quality	25
Cold Jet Services.....	26
Symbol Glossary	27
Warranty	29
Training Video.....	31





MODEL NO. 2A0169
VOLTAGE: 120/230 VOLTS AC

This manual illustrates the safety, operation, and maintenance features of the Cold Jet i³ MicroClean.

The build and revision level is located on the machine's data plate.

All Machine diagrams are located on the inside of the back panel.

The design contained in this manual was originated by and is the exclusive property of Cold Jet, LLC. It is not to be used in any way detrimental to the interests of Cold Jet, LLC.

No part of this design or manual may be reproduced, transmitted, stored in a retrieval system, or translated into any other language or computer language, in whole or in part, in any form or by any means, whether electronic, mechanical, magnetic, optical, manual or other, without the express written consent of Cold Jet, LLC.

SPECIAL NOTES

All information contained within this manual, or information derived from exposure to the technology or equipment supplied by Cold Jet, LLC remains "CONFIDENTIAL" between Cold Jet, LLC and the purchaser or authorized user. Any unauthorized transfer of information to any person or company not in the direct employ of Cold Jet, LLC, or not in the direct employ of the purchaser or the authorized user, is strictly prohibited.

"Cold Jet" and "i³ MicroClean" are registered trademarks of Cold Jet, LLC

Copyright 2009
Cold Jet, LLC
All Rights Reserved
Printed in U.S.A.
P/N: 2W0309-G1



SAFETY

GENERAL SAFETY PRECAUTIONS



- **NEVER OPERATE** the unit without first reading the Operator Manual.
- **NEVER EXPOSE** bare skin to CO₂ ice.
- **ALWAYS WEAR** thermal gloves, eye, and ear protection (safety glasses and ear plugs).
- **EVERYONE** in the blast area must comply with all safety requirements.
- **NEVER POINT** the nozzle at anyone and ALWAYS exercise extreme caution when people are in the blast area.
- **NEVER** use a wire tie to hold the applicator trigger in the **ON** position. Doing so can damage it and void its warranty.
- **NEVER USE** the blasting unit or hoses for anything except the intended usage.
- **ONLY USE** dry ice as the blasting media.
- **NEVER OPERATE** in a confined space without an approved ventilation system.
- **NEVER** operate the unit with guards removed.
- **NEVER** mask the machine's ventilation holes.
- **NEVER ALLOW UNTRAINED PERSONNEL** to operate the blasting unit.
- **NEVER OPERATE** a damaged blasting unit.
- **ALWAYS** turn the main power **OFF** and remove the applicator control cable **before** removing the blast hose.
- **NEVER** exceed recommended hose or blasting unit pressure levels.
- **ALWAYS** ground the material being cleaned.
- **ALWAYS ENSURE** that hoses are securely attached.
- **KEEP** hoses and power cord out of forklift traffic areas.
- **CHECK** hoses and cables for nicks and gouges.
- Do **NOT** kink the blast hose before or during operation.
- **NEVER DISCONNECT** the air supply hose without first shutting off the source air and bleeding lines.
- **ONLY COLD JET TRAINED** service technicians are allowed to work on the unit's electrical components.
- **ALWAYS** turn the application safety on before laying it down or passing it to someone.
- **DO NOT OPERATE** equipment with electrical parts exposed, jumpered or rendered inoperable.
- **ALWAYS** Follow the guidelines of the governing codes of your local/national body as a minimum standard for ensuring safety.

ELECTROSTATIC DISCHARGE

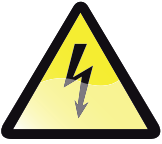

Electrostatic discharge can be hazardous to the operator and the equipment. The static charge of CO₂ varies with the amount of ice and humidity present. Follow these instructions to assure safe operation while blasting.

- A) The power outlet must have a good ground
This is critical for electrostatic dissipation. If the ground is not connected a charge will build up on the unit or the applicator.
- B) The static bonding cable must be attached between the blast hose and target surface
If a target is on a non-grounded surface it will build up an electrostatic charge, which could injure the operator or damage the equipment. Attach to hose and wrap or clip the cable to the target to dissipate the charge. Metal framing, that holds the target in place, can be used but the target and frame must be electrically connected. Use a conductivity tester for confirmation.
- C) Know your environment
Electrostatic buildup changes as humidity levels change and will vary by location. Electrostatic discharge is higher at low humidity levels and occurs most often during winter 32°F (0°C).

CARBON DIOXIDE

- This unit utilizes Carbon Dioxide (Dry Ice) as a blast media.
- Dry Ice is very cold, -110°F (-79°C), and may freeze skin instantly.
- CO₂ is a heavy gas, which means it will settle to the ground.
- Always ventilate when blasting.
- CO₂ is nontoxic, non-corrosive, non-conductive and is approved by the FDA and USDA. While exposure to CO₂ gas is not harmful in low concentrations, CAUTION must be exercised when using any material that can DISPLACE OXYGEN.

Carbon Dioxide (CO₂) is a naturally occurring gas and a normal by-product of breathing. However caution MUST be exercised!

ALWAYS USE PROTECTIVE CLOTHING (THERMAL GLOVES) AND EYE PROTECTION WHEN HANDLING CO₂ SOLIDS OR WHEN USING THE BLASTING UNIT.





COMPONENT GUIDE

FRONT VIEW

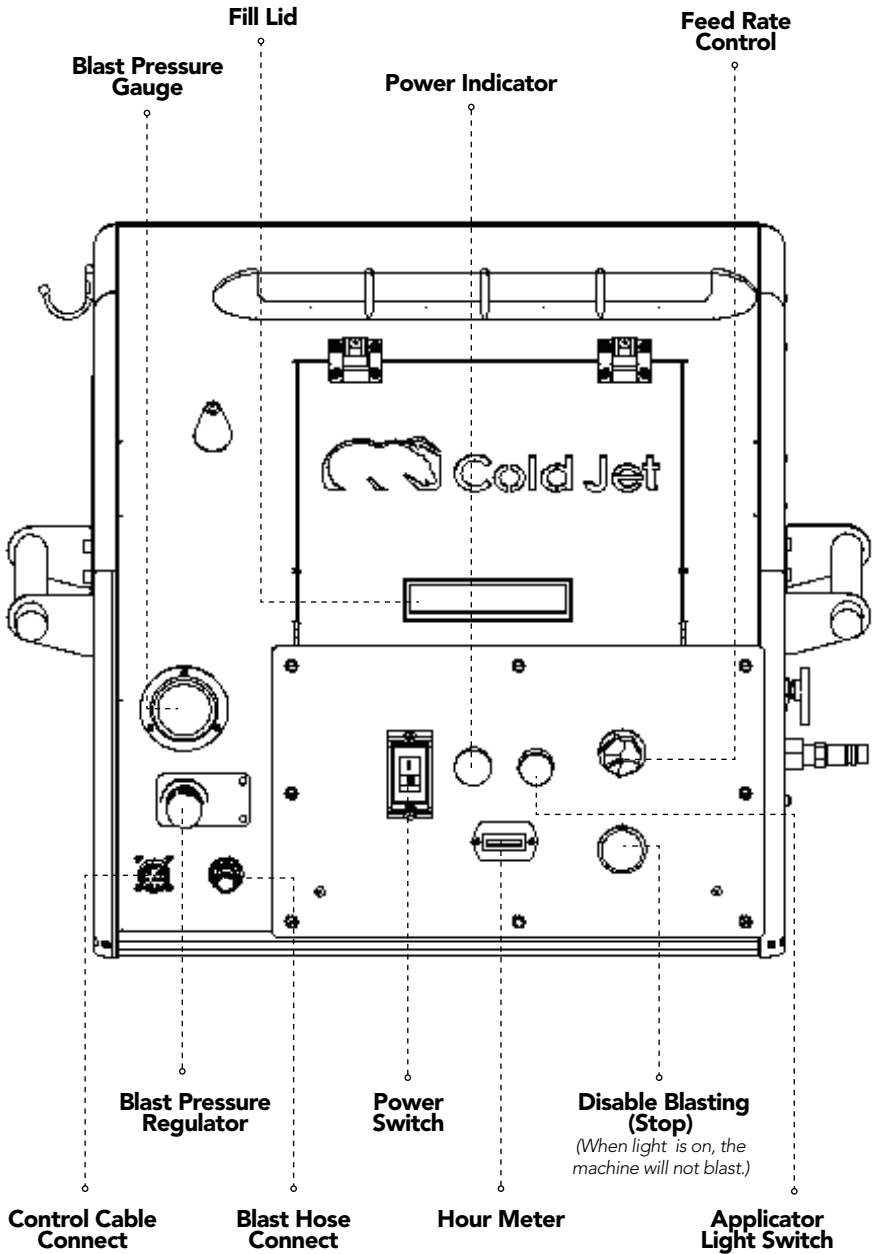

LEFT/RIGHT VIEW

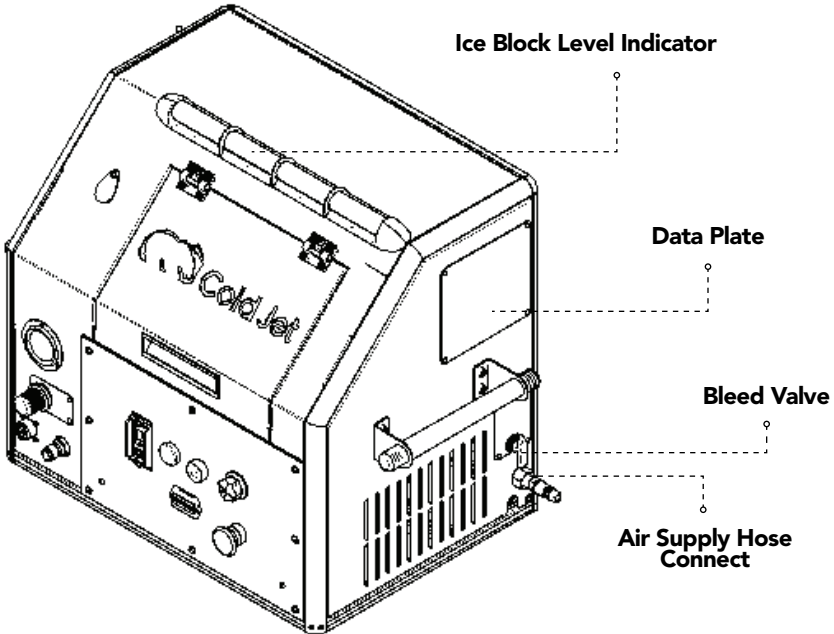
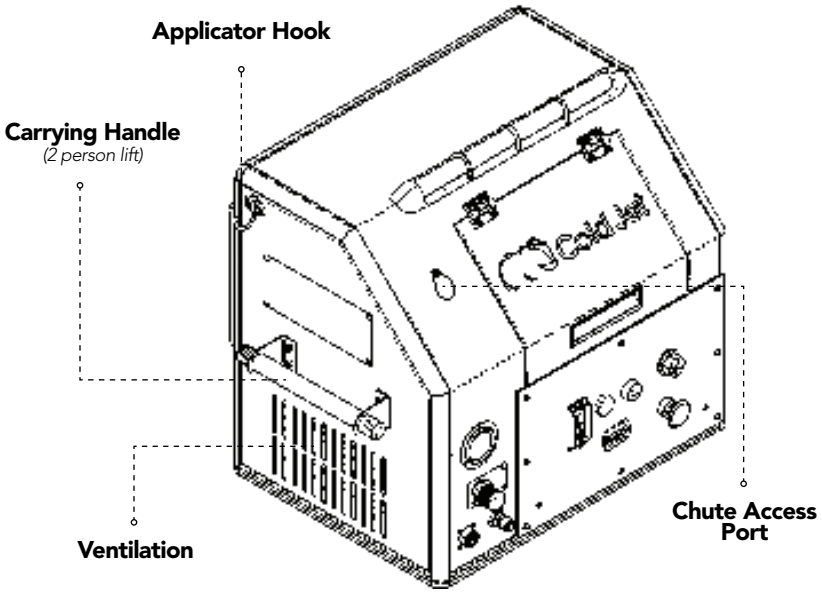

BLAST APPLICATOR

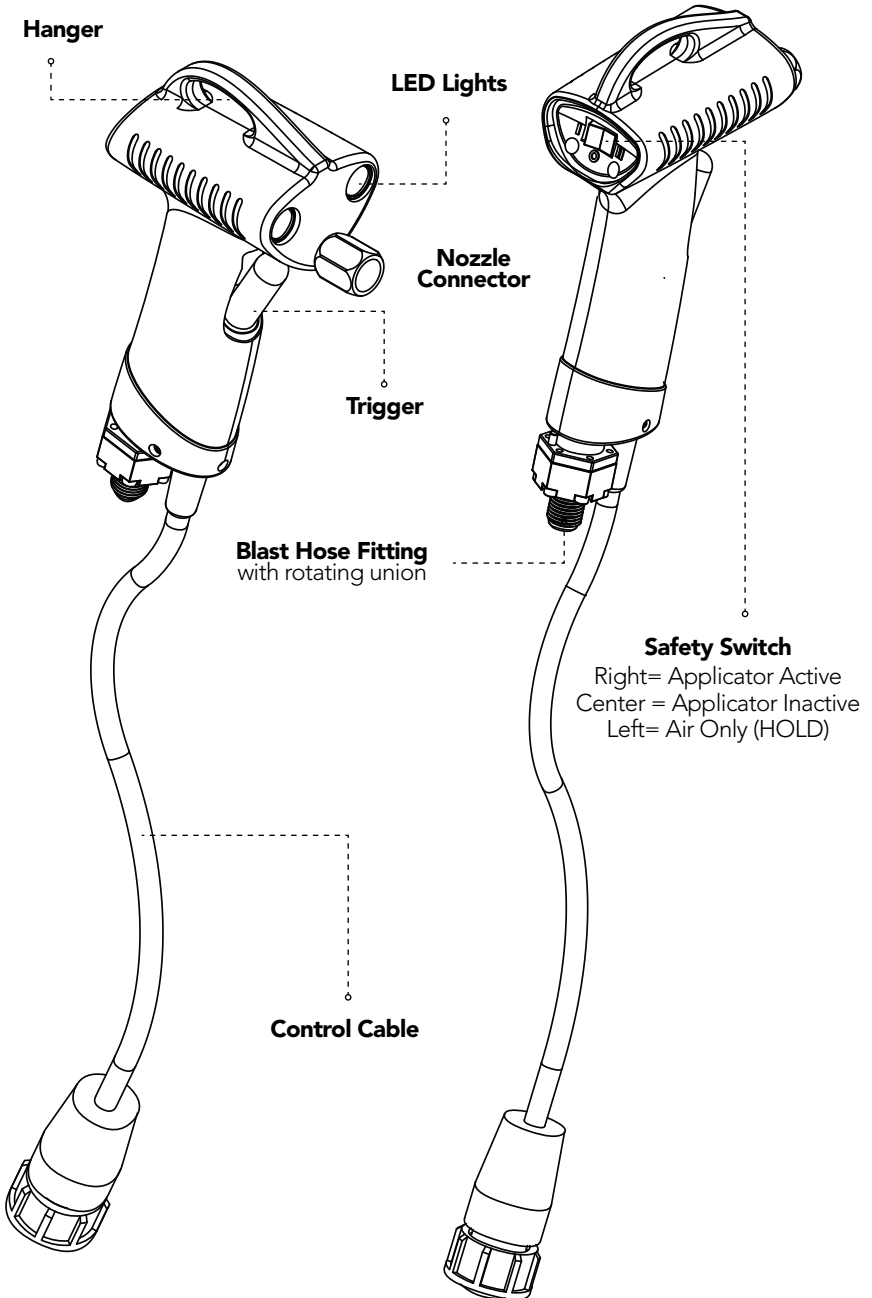

STANDARD CART

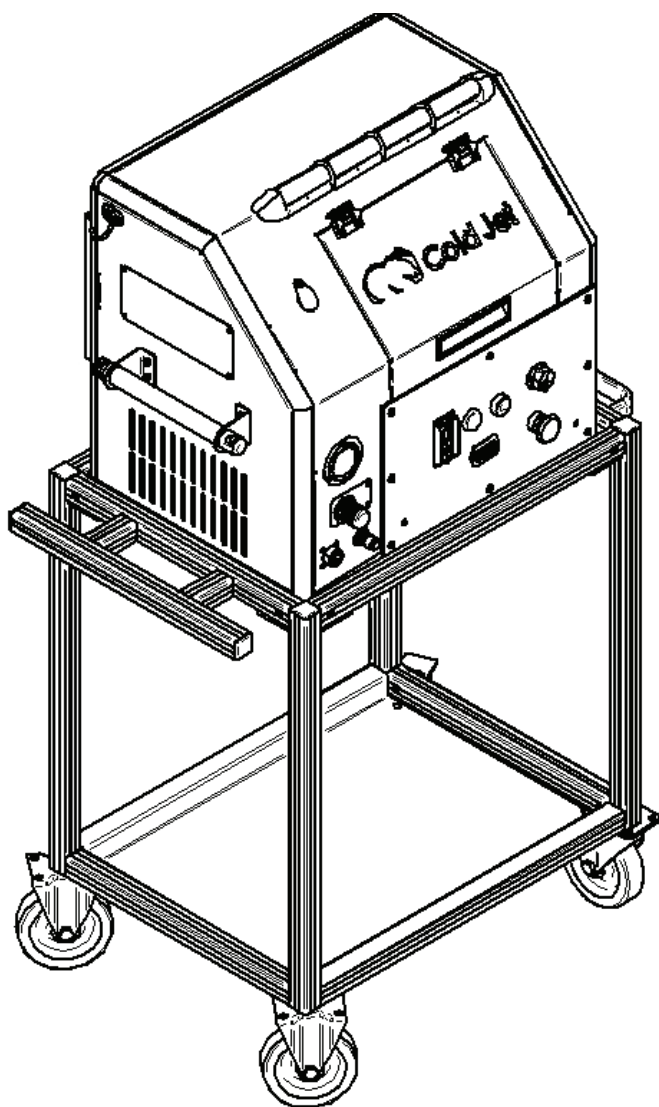



OPERATION

START UP

VERIFY THE FOLLOWING SUPPLY AIR PARAMETERS:

- The air pipe is at least a .5 in (12 mm) in diameter.
- The air pressure does not exceed 140 psig (9.7 bar).
- The air temperature does not exceed 122°F (50°C).

1. Make sure the power switch and bleed valve are OFF (O).
2. Securely attach the blast hose and control cable to the machine.
3. Securely attach the applicator to the blast hose and control cable.
4. Securely attach a nozzle to the blast applicator.
5. Attach the air supply hose to the air supply hose connect on the right side of the machine.

*Check the data plate for the operating pressure range.
Check the blast hose operating pressure.*

6. Make sure the ice trough is dry, clean, and free of debris.
7. Connect the static bonding cable to the blast hose and target surface or to an electrically conductive supporting structure.
8. Either turn on the air compressor or plug into an air drop and allow the air supply hose to pressurize. Check for leaks.

Plug the power cord into an electrical outlet. If an extension cord is necessary, it must comply with the power requirements of this unit and all governing electrical codes (Check the data plate for the operating voltage range).

10. Turn the power switch to the ON (I) position.
11. Turn the bleed valve ON (I) to purge water out of the lines, then turn it OFF (O) to close it.



If the supply air exceeds 140 psig (9.7 bar) then use an external pressure regulator

SHUT DOWN (FOR LONGER THAN 5 MIN)

1. Stop blasting and push the applicator safety switch toward the left to the center position.
2. Turn the power switch to the OFF (O) position to shut off the power.
3. Open the fill lid, move the pusher plate away from the dry ice block, remove the remaining ice from the trough, and close the lid.
4. Turn OFF the compressed air supply.
5. Turn the bleed valve ON (I) to evacuate all remaining pressure.
6. When the air hose is fully depressurized, disconnect all electric cables and hoses.

BLASTING

1. With the air hose pressurized and the unit ready,
2. Purge the system, of any debris, by blasting with air for 1 minute.

Before loading the dry ice block into the trough, turn the feed rate control to its maximum and squeeze the trigger while holding the safety switch to the left to purge the system.

After purging, return the feed control to zero then slowly increase the dial to the desired blast setting.

3. Verify that the pusher plate is pushed back to the end of the trough.
4. Place the dry ice block into the trough, against the rotary knives.
5. Close the fill lid.
6. Push the applicator safety switch to the right and squeeze the applicator trigger to blast.



Always purge the i³ MicroClean, before inserting the dry ice block, by blasting with compressed air.

BLASTING TECHNIQUE

- Position the blast hose for maximum maneuverability before blasting.
- Do not kink the blast hose.
- Hold nozzles perpendicular to the surface for fastest cleaning (recommended for most applications).
- Optimum stand off distance is 2 in (5 cm) for most nozzles.
- Never allow foreign objects to enter the ice trough!
- Do not abuse the blast applicator or cable.
- Reduce the feed rate to avoid clogging the nozzle at pressures below 50 psi (3.4 bar).
- To find optimum feed rate, set the feeder speed to 0 and increase the rate to achieve desired results.
- Blast with air only for 1 minute after breaks (to melt any water ice build-up inside the blasting unit).



MAINTENANCE

MAINTENANCE

DAILY MAINTENANCE

1. Drain water out of the lines before using the machine. (*Turn the bleed valve ON (I) to drain the water.*)
2. While in operation check the pressure gauge for damage.
3. Check the air and blast hoses for damage (*ie: cuts or scuff marks.*)



*If you are not an authorized Cold Jet Service Technician, please call to schedule service.
+1-800-777-9101 or
(+1-513-576-8981)*

WEEKLY MAINTENANCE

1. Check the rotary knives for wear and damage.
2. Make sure the nozzle airflow exit end is not deformed or burred.

MONTHLY MAINTENANCE

1. Check the air filter element.
2. This machine has been manufactured with a roller chain drive. **CAUTION: MAKE SURE ALL GUARDS AND PANELS ARE INSTALLED BEFORE OPERATING.**

The chain requires minimal maintenance. However, it should be lubricated monthly for maximum drive life.

For easy application of the lubricant (eg. Dupont™ Teflon™ Chain Saver Lubrication, McMaster Carr part no. 8710T35 for 14oz.), spray through the slotted vents on the left side panel.

BIANNUAL MAINTENANCE

1. Check pneumatic air lines
2. Check condition of power cord
3. Check all lights
4. Check static bonding cable
5. Check the accessories
6. Check all valves
7. Safety test the unit
8. Check chain tension

TROUBLESHOOTING

PROBLEM	CHECK THIS	SOLUTION
MACHINE WILL NOT POWER UP GREEN LIGHT IS NOT ON	Is the unit plugged in?	NO: Plug Unit in.
	Is the power switch in the ON (I) position?	NO: Push power switch to ON (I).
MACHINE WILL NOT BLAST	Is the BLUE DISABLE BLAST LIGHT on?	YES: Pull the disable blast button out.
	Is the applicator safety switch in the center position?	YES: Flip the switch right to deactivate safety.
	The Air Filter may be clogged.	Remove the back cover and replace the filter element.
	Is the air supply connected and the air supply on?	YES: The nozzle may be clogged.
	Is the blast pressure gauge showing pressure?	
	Is the applicator cable connected to the machine and the applicator?	To unclog the nozzle, blast with air only.
MACHINE BLASTS AIR BUT NOT SHAVED DRY ICE	Is the dry ice block behind the Pusher Plate?	YES: Push the plate to the back of the trough and reinsert the dry ice block.
	Do the rotary knives look damaged?	YES: Call Cold Jet for support.
	Is too much ice clogging the feeder?	YES: Open the Chute Access Port and blast with compressed air to break the clog.
	Is a foreign object lodged in the feeder.	YES: Call Cold Jet for support.

**IF THE SOLUTIONS LISTED HERE DO NOT SOLVE YOUR PROBLEM
CONTACT OUR CUSTOMER SUPPORT HOTLINE:
+1-800-777-9101 (+1-513-576-8981)**



APPENDIX

SPECIFICATIONS

Weight (empty):	130 lb (59 kg)
Dry Ice Capacity:	6 x 6 x 12 in (150 x 150 x 300 mm) 5 x 5 x 12 in (127 x 127 x 300 mm) with inserts
Dry Ice Delivery Rate:	Variable From: 0 - 1.2 lb/min (0 - .6kg/min)
Power Requirements:	100 - 140 VAC 1 Ø 50/60 Hz 5 A 200 - 240 VAC 1 Ø 50/60 Hz 5 A
Feeder Drive	1/4 Hp, 1.1 A, 230 VAC, 1,750 RPM, AC Motor
Blast Air Pressure	20 - 140 psig (1.4 - 9.7 bar)
Supply Pressure	50 psig (3.4 bar) minimum 140 psig (9.7 bar) maximum
Recommended Temperature	14° - 122° F (-10° - 50° C) (Operating) -4° - 149° F (-20° - 65° C) (Storage)

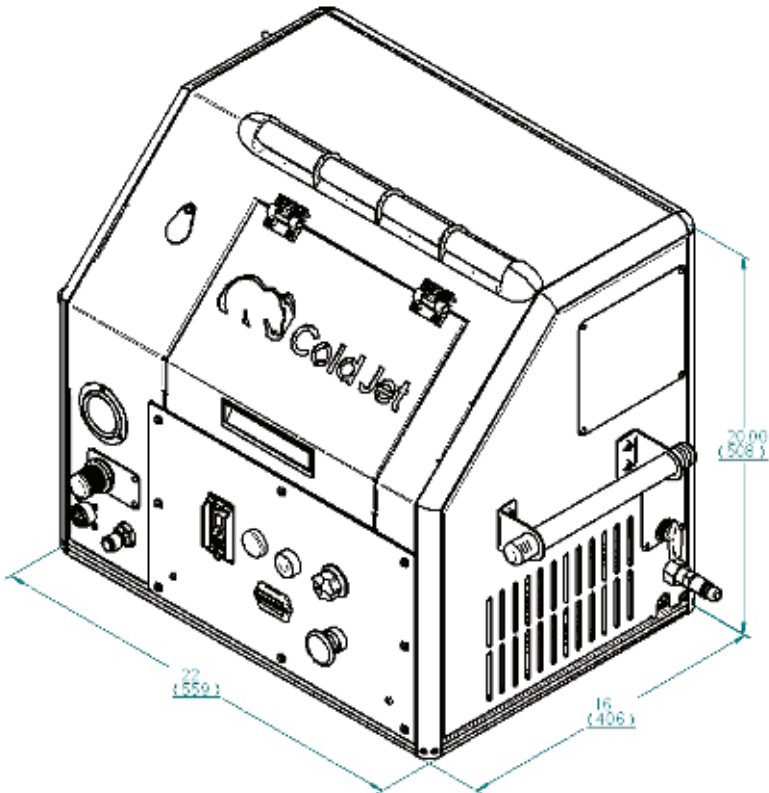

BLAST AIR QUALITY (UPTO 140 PSIG /9 .7BAR)

The Cold Jet i³ MicroClean works best when the supply air is free of any debris and has a dew point of -40°F (-40°C).

USING PLANT AIR (CENTRAL COMPRESSED AIR SYSTEM)

Manufacturing plants, with central compressed air systems, should have an after Cooler and a 2-stage coalescing filter assembly downstream of the receiver tank. Hot metal pipes are an indication this is needed.

To verify that the plant air system is adequate for the i³ MicroClean the air compressor needs to produce an air volume 10% greater than the i³ MicroClean's maximum air volume...in addition to the air volume consumed by normal plant operation.

To determine adequate air volume, blast while watching the pressure gauge.

- If the gauge drops slowly the compressor is insufficient.
- If the gauge drops quickly there is a restriction or the pipe is too small.
- If the gauge stays steady then the compressor and piping are adequate.

To maintain adequate pressure to the i³ MicroClean:

- From the air compressor to 50 ft (15 m) use a flexible .5 in (12 mm) air hose (preferably the hose supplied with the machine).
- From the air compressor to beyond 50 ft (15 m) make sure the pipe is .5 in (12 mm) in diameter before attaching the air hose.

If an air drop isn't used much, water and rust will collect in the line. Before plugging into the air supply, purge the line, to prevent contamination of the i³ MicroClean.

USING PORTABLE AIR (85 - 500 HP / 64 - 373 KW)

Portable air compressors are mainly used for shop tools, not dry ice blasting units and are therefore not able to cool or remove air moisture.

An after cooler with a 15°F (-9°C) approach is required to reduce the discharge air temperature 180°F (82°C) to within 15°F (-9°C) of ambient air temperature.

Without the after cooler, the following will occur:

1. Incoming air moisture will rapidly cool and freeze at the i³MicroClean's feeder.
2. Water ice will accumulate in the feeder, distorting the air flow and seal.

BLAST AIR QUALITY (CONTINUED)

3. Water ice buildup will continue inside the blast hose, to the nozzle.
4. Water ice will break off inside the hose and lodge in the nozzle, causing a jam.
5. Water ice, may exit the nozzle, and damage the target surface.

For the above reasons, an after cooler and moisture trap/filter must be used.

If blasting continuously, use an air dryer to further reduce the air moisture (dew point). Desiccant dryers produce a dew point of -40°F (-40°C), resulting in a dew point low enough for continuous blasting.

To verify the compressor is of adequate size for the i³ MicroClean the air compressor needs to produce an air volume 10% greater than the i³ MicroClean's maximum permissible air volume.

To determine adequate air volume, blast while watching the pressure gauge.

- If the gauge drops slowly the compressor is insufficient.
- If the gauge drops quickly there is a restriction or the pipe is too small.
- If the gauge stays steady then the compressor is adequate.

To maintain adequate pressure, the hose size from the compressor to the i³ MicroClean needs to be .5 in (12 mm) in diameter.





























COLD JET SERVICES

- Equipment upgrades
- Maintenance services and training
- Parts and service
- 24-hour technical assistance
+1-800-777-9101 or +1-513-576-8981
- Equipment rental
- Custom nozzle design
- Engineered solutions



- Allow 48 HOURS for delivery.
- Call +1-800-SEND-ICE (+1-800-736-3423) or +1-877-437-9423
- RETURN empty ice boxes promptly after use.
- Blocks are made using FOOD GRADE QUALITY dry ice.
- Manufacturers of dry ice block are located throughout the world (Belgium, Canada, France, Germany, Japan, Taiwan, Thailand...and more!) Call Cold Jet for details.

SYMBOL GLOSSARY

	General Danger		Variable Feed Rate		Lock Out/Tag Out
	Electric Shock or Electrocution		Enable Blasting		Disconnect Power
	Extreme Cold		Disable Blasting		Hour Meter
	Hand Crush from Side		Wear Ear Protection		Applicator Light
	Hand Cut from Impeller Blade		Wear Eye Protection		Blast Pressure
	Flying Debris		Read Operator Manual		Air Bleed
	Skin Puncture from Pressurized Air Jet		Wear Safety Gloves		CO ₂ Only
	Loud Noise		General Mandatory Action		
	Explosive Release of Pressure		Maintain Safe Pressure		
	Static Electricity		Do Not Operate with Guard removed		
	Chain Drive		No Foreign Objects		

(SOME SYMBOLS DO NOT APPLY TO THIS UNIT)



WARRANTY INFORMATION

Cold Jet® ("CJ") warrants its products ("Equipment") provided under this Agreement to be free from defects in materials and workmanship for a period of 12 months, under normal use, maintenance and service as stipulated in the Operator's Manual. CJ warrants that the equipment will be in good working order on the Date of Shipment and will conform to CJ's official published specifications.

The warranty period is 12 months for CJ manufactured Equipment. Original Equipment Manufacturers' warranties provided by CJ on equipment purchased under this Agreement not manufactured by CJ will be passed through to the Buyer. The warranty period commences on the Date of Shipment of the Equipment.

CJ's liability is limited to repairing or replacing, at its option, any covered part of its Equipment, which CJ has determined to be defective. Said repair or replacement will be made by CJ or its authorized representative free of charge to the Buyer, except for any freight or travel expenses, during the warranty period. Any replaced part will become the property of CJ. If, after repeated efforts, CJ is unable to restore its Equipment to good working order, or to replace the defective parts as warranted, CJ may, at its discretion, replace the Equipment in its entirety. Any claim must be made to CJ, in writing, within 30 days of discovering the defect and any claim not made within that period shall be deemed waived or released, and thus denied.

Warranty service provided under this Agreement does not assume uninterrupted operation of the Equipment. The suitability of the equipment for the purpose intended is not included in the warranty.

This warranty shall not apply and CJ shall be neither responsible nor liable for:

- A) Consequential, collateral or special losses or damages;
- B) Equipment conditions caused by abnormal conditions of use, accident, neglect or misuse of equipment, improper storage or damages resulting during shipment as determined by CJ;
- C) The replacement of normal wear items, including but not limited to air, blast and whip end hoses;
- D) Deviation from the Equipment's prescribed maintenance programs, replacement parts, operating instructions, specifications or other terms of sale;
- E) Labor charges, loss or damage resulting from improper operation, maintenance or repairs made by person(s) other than CJ or CJ-authorized service representatives;
- F) Improper application of the product. In no event shall CJ be liable for claims in excess of the purchase price, whether there is a breach of contract or warranty claim of negligence or negligent manufacture.

THIS WARRANTY IS THE SOLE WARRANTY OF CJ AND ANY OTHER WARRANTIES, EXPRESS, IMPLIED IN LAW OR IMPLIED BY FACT, INCLUDING ANY WARRANTIES OF MERCHANTABILITY AND FITNESS FOR PARTICULAR USE, ARE HEREBY SPECIFICALLY EXCLUDED.



TRAINING VIDEO





USA: +1 800.337.9423 +1 513.831.3211 • Belgium: +32 (0)13 53 95 47
Germany: +49 (0)6551 9606.0 • Canada: +1 800.337.9423 X501
Latin America: +52 (81)10 97 0445 • Middle East: +32 (0)13 53 95 47
www.coldjet.com